

Semi dried tomatoes and hepatitis A virus

Heather Craven, Lesley Duffy, Narelle Fegan and Alan Hillier

December, 2009

A report for the Department of Health, Victoria

Enquiries should be addressed to:

CSIRO Food and Nutritional Sciences, 671 Sneydes Road, Werribee, Victoria, 3030

Ph: 03 9731 3200; Fax 03 9731 3322

Copyright and Disclaimer

© 2009 CSIRO To the extent permitted by law, all rights are reserved and no part of this publication covered by copyright may be reproduced or copied in any form or by any means except with the written permission of CSIRO.

Important Disclaimer

CSIRO advises that the information contained in this publication comprises general statements based on scientific research. The reader is advised and needs to be aware that such information may be incomplete or unable to be used in any specific situation. No reliance or actions must therefore be made on that information without seeking prior expert professional, scientific and technical advice. To the extent permitted by law, CSIRO (including its employees and consultants) excludes all liability to any person for any consequences, including but not limited to all losses, damages, costs, expenses and any other compensation, arising directly or indirectly from using this publication (in part or in whole) and any information or material contained in it.

Contents

1. Summary and recommendations	4
1.1 Summary of the published information on hepatitis A virus survival and control.....	4
1.2 Summary of industry practices	6
1.3 Recommendations for the control of hepatitis A virus (HAV) in semi dried tomatoes	7
1.3.1 Recommendations to industry for immediate implementation.....	7
1.3.2 Recommendations for future strategies for managing contamination of HAV	8
1.3.3 Knowledge gaps and recommendations for future research	10
2. Literature Review: Hepatitis A virus survival and control	11
2.1 Introduction	11
2.2 Biology of HAV	13
2.2.1 General features of hepatitis A virus.....	13
2.2.2 Genotypes of HAV	14
2.3 Detection of HAV	15
2.3.1 Elution.....	15
2.3.2 Concentration	17
2.3.3 Detection of Virus	17
2.4 Survival of HAV on fresh produce.....	20
2.4.1 Impact of chilling and freezing on HAV	20
2.4.2 Effect of modified atmosphere packaging.....	22
2.5 Survival on inanimate surfaces.....	22
2.6 Survival and transfer of HAV in the environment.....	23
2.7 Survival and inactivation in water.....	25
2.8 Inactivation of HAV on produce	26
2.8.1 Decontamination by washing and disinfection.....	26
2.8.2 Effect of heat treatments on HAV	30
2.8.3 Processing technologies.....	33
2.9 Summary.....	34
3. Review of current Australian industry practices in the manufacture of semi dried tomatoes	35
3.1 Introduction	35
3.2 On farm practices	36
3.2.1 Australian grown tomatoes	36
3.2.2 Overseas grown tomatoes	38
3.3 Manufacturing Practices	38
3.3.1 Use of Australian grown tomatoes.....	38
3.3.2 Manufacture of semi dried tomatoes from imported tomatoes	42
3.3.3 Ingredients used in the manufacture of semi dried tomatoes.....	43
3.4 Implications of HAV on the manufacture of semi dried tomatoes.....	44
3.4.1 Changes in practice since HAV outbreaks	44
3.4.2 Suggestions from industry for control of HAV	44

3.4.3	Practices and procedures most at risk for introduction of HAV.....	46
References		47
Appendix A: project Scope		57
Appendix B: Australian tomato production statistics		59

List of Figures

Figure 1. HAV genome organization.	13
Figure 2. Harvesting tomatoes	38
Figure 3. Tomatoes on racks before drying	40

List of Tables

Table 1. Outbreaks of hepatitis A virus associated with fresh produce.....	12
Table 2 Detection methods for HAV.....	16
Table 3. Survival of hepatitis A virus on fresh produce during storage	21
Table 4. Effect of different disinfectant treatments on hepatitis A virus on produce	28
Table 5. D and Z values for inactivation of hepatitis A virus in synthetic media or fruit-based products as a function of the sucrose concentration.....	31
Table 6. Effect of different heat treatments on hepatitis A virus on produce and impact of viral strain	32
Table 7. Seasonality of tomato growth in Australia	36
Table 8. The percentage of Australian tomato production per state for 2007-2008 (based on Australian Bureau of Statistics data)	59
Table 9. Area used for growth and tonnage of tomato production in Australia for 2007-2008 (based on Australian Bureau of Statistics data).....	60

1. SUMMARY AND RECOMMENDATIONS

1.1 Summary of the published information on hepatitis A virus (HAV) survival and control

A literature review was conducted to determine the current state of published knowledge on methods for controlling food borne viruses in horticulture products as per the scope listed in Appendix A. There are no straight forward means for eliminating Hepatitis A virus (HAV) on fresh produce and protection against viral contamination will rely on implementation and adherence to controls which prevent contamination from humans who are the primary carrier of the virus. Therefore good agricultural and manufacturing practices to eliminate direct transfer from infected personnel or indirect transfer from contaminated equipment surfaces or water is essential. This can be best achieved through appropriate hygienic behaviour of farm and factory personnel, thorough cleaning, sanitation and disinfection of equipment surfaces and adequate protection of water supplies that might contact product. Processes such as washing, sanitising, heating and the use of various processing technologies have been reported to inactivate HAV to varying degrees in different food types. However very few reports have focussed specifically on the inactivation of HAV on tomatoes. The methods used for recovering and detecting HAV in inactivation studies vary greatly and can impact on the results of experiments. Direct comparisons between different reports is therefore not possible. Hence the information contained in this report relating to the inactivation of HAV may not be applicable or appropriate for the manufacture of semi dried tomatoes. Below is a brief summary of the most important points arising from the review of the published literature on HAV in relation to horticulture products.

General

- HAV is an RNA virus in the genus *Hepatovirus* within the family *Picornoviridae*
- There is only one serotype of HAV which can be further discriminated into three genotypes based on sequence differences
- HAV infects humans and is transferred via the faecal oral route
- Most outbreaks of HAV associated with produce appear to have occurred as a result of cross contamination from an infected food handler

Detection of HAV

- Wild type HAV is difficult to detect using tissue culture techniques
 - HAV requires an extensive adaptation period before it grows in cell cultures

- Most laboratory based tests to study the survival and inactivation of HAV use an adapted strain able to grown in foetal rhesus monkey cells
- Detection in food samples is based on detecting the viral RNA
- Detection requires elution of the virus from the food, concentration of the virus and detection of the viral RNA after extraction and amplification, or tissue culture assay if using a strain adapted to infect cell cultures
- There is a need for a standard method for virus detection

Survival of HAV on produce

- The type of product has a large impact on the ability of the virus to survive (e.g. survival on lettuce is longer than survival on fennel or carrot during chilled storage)
- HAV tends to be more resistant to inactivation (through freeze drying and sanitising) on produce with rougher surfaces (raspberries, blackberries, strawberries, parsley) than those with smother surfaces (blueberries)
- Chilling and freezing have little impact on HAV survival on produce
 - chilling has a limited impact on HAV survival and is product dependant (anything from < 1 up to $4 \log_{10}$ decrease over a week)
 - freezing (for periods of up to 90 days) does not cause significant reduction in numbers of HAV (usually less than $1 \log_{10}$)
- Survival during storage is greater at lower temperatures (e.g. $4 \text{ }^{\circ}\text{C}$) than at higher temperatures (e.g. $22 \text{ }^{\circ}\text{C}$)
- The numbers of HAV likely to be present on raw produce are unknown, therefore the level of HAV inactivation required to eliminate infectivity is unknown

Inactivation of HAV on produce

- Survival and inactivation of different food borne viruses varies depending on the virus and HAV generally tends to be amongst the more resistant viruses
- The effectiveness of washing and use of sanitisers and disinfectants is dependant on the type of produce
- Washing in water alone reduces HAV levels by up to $1 \log_{10}$
 - including a sanitiser (such as chlorine) in the wash can increase the level of reduction

SUMMARY AND RECOMMENDATIONS

- Chlorine based sanitisers appear to be more effective against HAV than others (such as peracetic acid, iodine based products and alcohols) on both produce and inanimate surfaces
 - 20 ppm free chlorine for 3 min or more can reduce HAV levels on cherry tomatoes in laboratory based experiments by more than 2.4 log₁₀ (higher levels such as 200 ppm are also effective)
 - maintaining the appropriate contact time is critical for inactivation
- Heat inactivation of HAV varies depending on the product being heated
 - most of this research has investigated the effect of heat on HAV survival in milk, shellfish homogenate and in suspension
 - very little work has been published on the effect of heat on survival of HAV in fruits and vegetables
- Fat and sugar contents of food can protect HAV from inactivation using heat (if applying heat treatment for reducing HAV need to consider components of food)
- High pressure processing, ultra violet light and high intensity pulsed light show some promise for inactivating HAV (> 4 log₁₀ reductions) on some types of fresh produce though further research into the commercialisation of these technologies for application to produce and their effects on quality is required

Transfer and preventing cross contamination of HAV

- HAV can survive in soil and water for extended periods of time (several weeks or longer depending on temperature, and the components of soil and water)
- Transfer of HAV can occur from one person to another via fingerpads, from fingerpads to surfaces (such as stainless steel and lettuce) and from surfaces to fingerpads
- Washing hands and fingerpads will reduce the number of infectious HAV by between 77 and 92%
- Washing hands with water, topical agents and alcohol based solutions can significantly reduce levels of HAV transferred to produce and stainless steel

1.2 Summary of industry practices

A total of 12 companies associated with the semi dried tomato industry were either visited or phoned to provide information on current industry practices. In general the industry follows the practices below

- Growers all have documented procedures, quality manuals and HACCP plans
- Fresh tomatoes are
 - treated with halogen sanitisers on the farm for mould prevention and shipped chilled
 - rinsed in 200 ppm chlorine with various contact times at the manufacturer before cutting
 - sorted onto drying racks by hand
 - dried at various time/temperature combinations depending on end product requirements
- Frozen product arrives semi dried from either Australian or overseas sources and is defrosted over 3-4 days before use
- Product is dressed with canola oil or vinegar and various herbs, garlic and salt
- All manufacturers have HACCP plans in place that are regularly audited
- All manufacturers have end product testing (e.g. for microorganisms and pH) but large variations in frequency and tests applied were noted

1.3 Recommendations for the control of HAV in semi dried tomatoes

1.3.1 Recommendations to industry for immediate implementation

The greatest impact for reducing HAV contamination of semi dried and semi sun dried tomatoes will be to ensure that human faecal contamination of product does not occur. Once present in the product the virus is difficult to inactivate with certainty as the extent of contamination can not be determined with accuracy and there are no validated protocols for inactivation of HAV in semi dried tomatoes. As such, the major recommendations from the information gathered as part of the literature review and current industry practices focus on ensuring good agricultural and manufacturing practices are applied to prevent contamination from relevant human sources and activities. Reviewing current practices to ensure hygienic practices are in place and reinforcing these is likely to be the most appropriate and cost effective means for industry to control HAV as most manufacturers already have such protocols in place. Attention to hygiene is necessary to eliminate the opportunity for faecal contamination of tomatoes at all stages of production. There is little evidence from the literature to indicate there is an effective inactivation process for semi dried tomatoes as most reports relating to fresh produce have focussed on lettuce, green onions, herbs and berries and the behaviours of HAV differs on different types of produce. The major recommendation for immediate implementation by the industry is:

- Maintain good agricultural and manufacturing practices at all stages
 - Ensure strict personal hygiene (from growing of tomatoes through harvest and manufacture of semi dried product)
 - through provision of readily accessible hand washing/sanitising stations at entrances to growing or manufacturing areas
 - protective barrier apparel with regular training in their use and management supervision for all who contact the product
 - readily accessible toilet facilities with hand washing/sanitising facilities must also be provided
 - Ensure proper cleaning of surfaces coming into contact with product and ingredients to prevent cross contamination
 - Monitor washing of produce and equipment to ensure appropriate levels and contact times of sanitisers/disinfectants are used at all stages of production and manufacture
 - Ensure only water of potable quality (as per the Food Standards Code) is used to rinse tomatoes or the surfaces that they contact after sanitising steps
 - Prevent cross contamination from other products, ingredients and from the movement of staff, especially where the risk of HAV contamination is unknown
 - Ensure traceability of all ingredients used in the manufacture of semi dried tomatoes is maintained throughout production and manufacture and appropriate records kept
 - Define batches of product appropriately to allow complete traceability of all ingredients comprising each batch
 - Ensure process information and food safety plans are available for both domestic and imported product

1.3.2 Recommendations for future strategies for managing contamination of HAV

The establishment of an industry association covering all interested parties in the manufacture of semi dried and semi sun dried tomatoes would be of benefit in dealing with future issues facing the industry as a whole. This association could be involved in developing practices that benefit all manufacturers across the industry including both importers and those who manufacture from domestic product. It appears there is no clear definition of what constitutes the product semi dried tomatoes and semi sun dried

tomatoes. Defining the product is an important step to develop an industry code of practice for the manufacture of semi dried tomatoes. The code of practice should apply to all manufacturers of semi dried tomatoes including those that exclusively use domestically grown produce, those who exclusively import product grown overseas and those that use a mix of both domestic and imported product. This may require the development of separate codes of practice to meet the needs of all manufacturers. Recommendations for future development by the industry include:

- Establish an industry association that is representative of all interested parties and covers all scales of production (including importers, those using domestic product and those using a mix of both)
- Define semi dried and semi sun dried tomatoes – there is currently no specific definition for the product “semi dried tomatoes” or “semi sun dried tomatoes”
- Develop an industry wide code of practice for the manufacture of semi dried and semi sun dried tomatoes
 - needs to cover manufacturers using imported product and those using domestic product and those using a mix of both domestic and imported products
 - consideration should be given to the range of production practices used in the manufacture of semi dried tomatoes

It is possible that some semi dried tomatoes which have not been produced by HACCP accredited manufacturers may enter Australia. Although there was no evidence of this obtained during the current study and the amount of product is likely to be small, it does pose a risk for introduction of HAV. It is therefore recommended that:

- The industry take steps to eliminate import of uncertified tomatoes

It would be of benefit to all industries implicated in HAV outbreaks if there was a certified testing facility for HAV available within Australia. It would be an additional benefit if this facility had the ability to sequence specific regions of the genome of HAV isolated from clinical samples and foods to establish epidemiological links between implicated product and clinical cases. Such a facility would enable more rapid assessment of results. A recommendation for future consideration by government or commercial testing laboratories is to:

- Establish a facility in Australia that is certified for testing for HAV in both clinical and food samples. Ideally this laboratory would also have the capability for sequence typing of the virus to assist in establishing links between implicated product and clinical cases

1.3.3 Knowledge gaps and recommendations for future research

Methods for detection of food borne viruses, including HAV, are difficult to conduct and require specific equipment and skilled staff. There are no standard methods for the detection and enumeration of HAV in foods. This makes it difficult to compare between the results of investigations into the impact of sanitisers, disinfectants, heat treatments and other processes for inactivation of HAV. As such, the following is recommended:

- Appropriate methods for testing of HAV need to be developed and validated for use on tomatoes and semi dried tomatoes

There is very little known about the behaviour of HAV in relation to the production practices (sanitisers, drying times and heating temperatures) used in the manufacture of semi dried tomatoes. In particular there is a lack of information on the survival and inactivation of HAV specifically on tomatoes. Therefore the following research activities could be undertaken to assist the industry in determining the impact of current production practices on HAV inactivation:

- Understand the impact of different sanitisers and disinfectants on inactivation of HAV specifically on tomatoes to limit introduction of HAV on incoming product
 - appropriate levels and contact times for chlorine and other potential sanitisers for inactivation of HAV on tomatoes during washing
- Understand the impact of different heating and drying conditions used in the manufacture of semi dried tomatoes on HAV

2. LITERATURE REVIEW: HEPATITIS A VIRUS SURVIVAL AND CONTROL

2.1 Introduction

Food borne viruses have become a significant cause of food associated outbreaks and hepatitis A virus (HAV) is one such pathogen. HAV infects humans exclusively and has not been isolated from animals other than some non-human primates. The virus cannot grow outside the human host so its numbers do not increase once outside the human body. Outbreaks of HAV can result from water which may have been contaminated by human faeces (through untreated sewage or failures in sewage treatment systems) or via food which may have become contaminated either directly from infected humans or from contact with contaminated water. Many food associated outbreaks of HAV have resulted from consumption of shellfish which concentrate the virus when they are grown in contaminated waters. Contamination of the water (both fresh and seawater) can occur from untreated or improperly treated sewage effluent. The other high risk food products associated with outbreaks of HAV include those foods which are minimally processed before consumption. Many outbreaks of HAV have been associated with fresh produce (Table 1) and other foods sold in restaurant settings or at retail. These include baked goods, deli products, raw beef, liver pate, ice cream and dried fruits (Schoenbaum et al. 1976; Becker et al. 1996; Weltman et al. 1996; Howitz et al. 2005; Prato et al. 2006; Schenkel et al. 2006; Hasegawa et al. 2007; Schwarz et al. 2008; Cao et al. 2009; Robesyn et al. 2009; Schmid et al. 2009).

In most outbreaks associated with fresh produce where the source of contamination has been determined, food handlers involved in harvesting or preparing foods have been identified as the source (Table 1). Infected food handlers have also been responsible for outbreaks of HAV associated with other food vehicles (Prato et al. 2006; Schenkel et al. 2006; Hasegawa et al. 2007; Heywood et al. 2007; Perevoscikovs et al. 2008; Schwarz et al. 2008; Robesyn et al. 2009; Schmid et al. 2009). Tracing the source of outbreaks is difficult due to the long incubation period of the virus leading to difficulties in obtaining implicated food products for testing and for patients to recall the foods consumed during the incubation period. Investigation of the source of outbreaks of HAV has been assisted through determining the relationships between the types of HAV in clinical cases using sequencing of viral RNA (Prato et al. 2006; Cao et al. 2009; Park et al. 2009). Because foods such as fresh produce have been associated with HAV outbreaks it is important to understand the factors involved in contamination of produce and the impact of storage and any processing treatments on the survival and inactivation of HAV. The information in this report provides an overview of the available published literature in relation to the survival and inactivation of HAV with respect to fresh produce.

LITERATURE REVIEW: HEPATITIS A VIRUS SURVIVAL AND CONTROL

Table 1. Outbreaks of hepatitis A virus associated with fresh produce

Suspected source	No. Cases	Country	Setting	Year	Detected from foods ^a	Suspected reasons/comment	Reference
Salads and sandwiches	15	Melbourne, Australia	Restaurant	2008	NT	Infected food handler	(Rowe et al. 2009)
Salad, fresh vegetables	15	St Petersburg, Russia		2005	NR	Infected food handler	(Mukomolov et al. 2008)
Various including leafy salads	17	Ontario, Canada	Restaurant	2005	NR	Infected food handler	(Heywood et al. 2007)
Orange juice	351	Egypt	Hotel, restaurant	2004	no	NR	(Frank et al. 2007)
Green Onions	422	TN, NC, GA, USA	Restaurant	2003			(Amon et al. 2005; Wheeler et al. 2005)
Blueberries	81	NZ	Retail	2002	yes	Possible faecal contamination	(Calder et al. 2003)
Sandwiches	46	Massachusetts, USA	Restaurant	2001		Infected food handler	(LaPorte et al. 2003)
Green onions	43	Ohio, USA	restaurant	1998	No	Single restaurant only	(Dentinger et al. 2001)
Strawberries (Frozen)	242	Multistate, USA	schools	1997	no	Infected food handler at harvest	(Hutin et al. 1999)
Strawberries (Frozen)	57	Georgia, Montana, USA	School	1990	no	Infected food handler at harvest	(Niu et al. 1992)
Iceberg lettuce	202	Kentucky, USA	Restaurants (same supplier)	1988	no	Contamination occurred prior to distribution	(Rosenblum et al. 1990)
Raspberries (Frozen)	5	Scotland	Home	1988	no	Infected food handler at harvest	(Ramsay and Upton 1989)
Raspberries (Frozen)	24	Scotland	home	1983	No	Infected food handler at harvest	(Reid and Robinson 1987)
Lettuce salad	103	Florida, USA	restaurant	1986	no	Infected food handler	(Lowry et al. 1989)
Orange juice (reconst.)	24	Missouri, USA	Hospital	1962	NR	Infected food handler	(Eisenstein et al. 1963)

^a NT – not tested, NR – not recorded

2.2 Biology of HAV

2.2.1 General features of hepatitis A virus

Hepatitis A virus (HAV) is a non-enveloped, icosahedral virus around 30 nm in diameter. It belongs to the *Hepatovirus* genus within the family *Picornaviridae* and is a positive-strand RNA virus with a genome of 7462 – 7463 nucleotides. The genome contains a single open reading frame (ORF) surrounded by a 5' untranslated region of about 750 nucleotides and a shorter 3' untranslated region that contains a poly (A) (Figure 1).

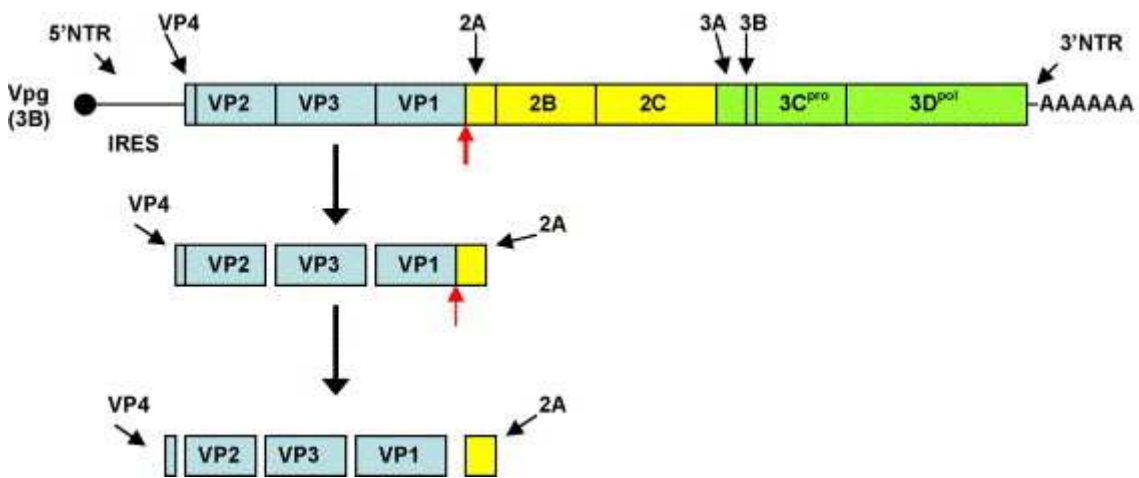

Figure 1. HAV genome organization. The positive-strand (messenger-sense) RNA genome contains a single open reading frame encoding a polyprotein that is proteolytically processed by the viral protease 3C^{pro}. A yet to be identified cellular protease cleavage in VP1-2A is indicated by a red arrow. Structural proteins (VP1-4) are indicated in blue, non structural proteins (P2 and P3) and indicated in yellow and green, respectively. From Cristina and Cost-Mattioli (2007).

The 5' untranslated region contains signals for the initiation of translation (an internal ribosome entry site) and transcription of the RNA (Nainan et al. 2006). P3A (VPg) binds to the 5' end of the RNA (on the viral plus and minus strands and the double stranded replicative form,) and is involved in transcription initiation (Weitz et al. 1986)

The polypeptide is divided into 3 major functional regions designated P1, P2 and P3 (shown in blue, yellow and green respectively in Figure 1. During translation, the polypeptide undergoes staged proteolytic cleavage, catalysed primarily by the viral protein 3C^{pro}, to form 11 smaller peptides. The viral proteins VP1-VP4, located at the N terminus of the polypeptide represent the virus capsid proteins. HAV differs from other *Picornaviridae* by having a smaller VP4, which has not yet been isolated in mature virus particles (Probst et al. 1999).

The peptides released from P2 and P3 are non-structural, Protein P2A is involved in morphogenesis (Probst et al. 1999), P3A binds covalently to the 5' end of the RNA

(Weitz et al. 1986), 3C^{pro} is the viral protease (Jia et al. 1991) and 3D^{pol} is the RNA dependent RNA polymerase (Cohen et al. 1987; Tesar et al. 1994).

2.2.2 Genotypes of HAV

Antibodies to human HAV are unable to distinguish between individual strains of HAV and only a single serotype of HAV has been documented. This is due to the extensive conservation of amino acid sequence in the capsid proteins of HAV. The original genotyping of HAV by Robertson et al (1992) was based on the nucleotide sequence of a 168 nucleotide region that spans the VP1/2A junction. 152 strains from a variety of geographical regions and including both human and simian isolates were grouped into seven major genotypes. The genotype was defined “as a group of viruses having nucleotide sequences which differ from each other at no more than 15% of base positions” (Robertson et al. 1992). Four of the genotypes (I, II, III and VII) were associated with human disease, while genotypes IV, V and VI were associated with monkeys. Genotype III was isolated from both human and simian sources. Genotypes were further divided into subgroups (A and B) that differed from each other at approximately 7.5% of nucleotides in this region. Subsequent analyses have identified that the group VII virus were more closely aligned with group II and are now considered as a subgroup (IIB) of group II (Lu et al. 2004a). With this exception, comparison of the initially identified groups by complete genome sequencing has confirmed the original genotypic classification of the virus and allowed more finely tuned phylogenetic trees to be constructed (Ching et al. 2002; Lu et al. 2004b; Endo et al. 2007b). The degree of discrimination provided by sequence information provides the only effective tool for studying the epidemiology of HAV outbreaks. Comparison of entire genomic sequences from 21 isolates including all groups/subgroups shows nucleotide identities of 80.7 - 86.6% at the genotype level, 89.1 - 91.9% at the subgenotype level and 94.6 - 99.7% at the isolate level (Endo et al. 2007a).

Alignment of the genomic sequences of HAV belonging to all genotypic/subgenotypic groups has allowed the design of primers for PCR based detection and characterisation of the virus. On this basis, Endo et al (Endo et al. 2007a) identified a region of 481 nt spanning the VP1-2B region of the genome, and a 590 nt region spanning the 3C/3D junction as areas which had significant areas of variability, surrounded by conserved regions, allowing the design of PCR primers for the amplification and characterisation of these regions. Determination of the sequence of these amplicons provides useful information on the relatedness of virus for epidemiological studies.

Other authors have used regions of the 5' untranslated region to detect HAV virus, as this region is relatively conserved between HAV genotypes (Costafreda et al. 2006). While this allows for certainty in the design of primers for detection of the virus, it does not provide useful information on the genotype of the virus and sequence information derived from the amplicons cannot be used for phylogenetic characterisation.

2.3 Detection of HAV

The detection of HAV from food and environmental samples is generally considered to involve three stages (Croci et al. 2008): (i) elution of the virus from the contaminated sample and clarification of the eluted sample; (ii) Concentration of the virus and (iii) detection of the virus. However currently there are no standard methods for the detection of HAV in foods (Serracca et al. 2009). It has been suggested that it is unlikely that a single international standard is likely to be developed because of the effect of differences in morphology, and hydrophobic interactions of various foodstuffs with viruses, and the effect of food composition (PCR inhibitors) on the detection of HAV via PCR type reactions (Croci et al. 2008). A summary of procedures used to detect HAV is shown in Table 2. Various authors have shown that the efficiency of recovery of HAV at each step is variable. This is best exemplified by the study of Costafreda et al. (2006) who used samples spiked with mengovirus or HAV ssRNA to determine recoveries at each step of the process. This data indicated recovery of mengovirus from the shellfish with an efficiency of ~ 0.1%. The data also suggested that there was considerable sample to sample variation, particularly in the RNA extraction step. The real time reverse transcriptase TaqMan assay detected 10 ssRNA molecules, 1 viral RNA molecule or 0.05 infectious virus particles per reaction. When used to estimate the HAV titre of shellfish samples associated with a genotype 1B outbreak, the assay was able to detect 4.4 ssRNA molecules, which equated to 7.5×10^3 genome copies /g hepatopancreas. Overall, when the efficiency of each step in the process was taken into consideration, the limit of detection was 6.6 genome copies per g of hepatopancreas.

2.3.1 Elution

HAV particles are positively charged at neutral pH and below (Sanchez et al. 2004), and most elution buffers therefore use a pH > 7.0 (range 7.4 – 9.5). Dubois et al (2006) compared various elution buffers and concentration steps on the elution of HAV from lettuce. These authors tested elution of HAV with water (pH7.0), phosphate buffered saline (pH 7.4), 50 mM glycine (pH9.5), 50 mM glycine 150 mM NaCl (pH9.5) and 100 mM Tris 50 mM glycine (pH 9.5). Recoveries ranged from 27.4 % for 50 mM glycine, 150 mM NaCl to 156% for 100mM Tris 50 mM glycine (emphasizing the variability in detection methods). These authors reported 63% recovery of HAV from lettuce leaves, after acidification of the elution buffer to pH 3.5 followed by filtration through an electronegative filter and using a plaque forming assay to quantitate the virus. Previously Dubois et al. (2002) had identified that the recovery of HAV from fruits such as raspberries was decreased if the buffering capacity of the elution buffer was not sufficient to maintain the pH > 7. This required the use of 100 mM or 500mM Tris buffer, in combination with 50 mM Glycine, and 3 % beef extract pH 9.5. The authors reported that the use of these buffers followed by PEG precipitation resulted in 20.1 % recovery of HAV from fruits. The buffer used for elution of HAV from spinach leaves was also found to impact on the recovery of HAV (Shieh et al. 2009).

LITERATURE REVIEW: HEPATITIS A VIRUS SURVIVAL AND CONTROL

Table 2. Detection methods for HAV

Food Stuff	Extraction Medium	Concentration step	Virus detection method	RNA extraction	PCR detection method	Sensitivity	Comment	Primers	Reference
Green onion	250 mM Tris, 1.92M glycine	PEG precipitation	RT-PCR	Acid guanidinium thiocyanate-phenol-chloroform	RT-PCR (EtBr stained gel) TaqMan Nested PCR	20 PFU 0.2 PFU			(Hu and Arsov 2009)
Tomato sauce, strawberries	50 mM Glycine, 140mM NaCl pH 7.5	PEG precipitation	RT-PCR	Guanidinium thiocyanate , RNeasy column	One step RT-PCR Nested PCR (EtBr stained gel)	14 PFU / g (tomato sauce) 33 PFU/ g (strawberries)		VP1-VP3 capsid region	(Love et al. 2008)
Purified Virus			RT-PCR	QIAGEN Trizol FTA cards	One step RT-PCR (EtBr stained gel) TaqMan	10 ⁻² diltn 10 ⁻¹ diltn nd		3C protease region	(Brassard et al. 2009)
Stool Serum Shellfish	PBS, BSA Triton X100 (Stools,serum) CHCl ₃ butanol Cat flocc T (Shellfish)	Nil (stools, serum) PEG precipitation (Shellfish)	RT-PCR	QIAGEN RNeasy		7.5 X 10 ³ -7.9 x10 ⁵ HAV genomes / g digestive tissues	Numbers estimated using spiked mengovirus as an internal standard	5' untranslated region	(Costafreda et al. 2006)
Lettuce Strawberries	PBS (pH 7.6)	Immuno magnetic beads +ve charged filter (Vriosorb)	RT-PCR	Titan kit	RT-PCR (including directly from beads) (EtBr stained gel)	0.5 – 10 PFU		VP3-VP1 region (Capsid protein)	(Bidawid et al. 2000c)
Shellfish	90 mM glycine 10 mM NaOH (pH 8.8)	Antigen capture on microtubes	RT-PCR	Lysis at 95°C	RT-PCR (EtBR stained gel)	0.05 PFU		VP3-VP1	(Deng et al. 1994)

2.3.2 Concentration

HAV have been concentrated from elution buffers by a variety of techniques which are influenced by the source of the virus. For example, viscous samples are difficult to filter, and it is important as much as practicable to minimise the co-concentration of PCR inhibitors with the virus. Techniques that have been used to concentrate HAV include PEG precipitation (Love et al. 2008; Hu and Arsov 2009), immunomagnetic beads and positively charged virosorb filters (Bidawid et al. 2000c), positively charged magnetic beads (Papafragkou et al. 2008), and ultracentrifugation (Rzeutka et al. 2006).

Bidawid et al. (2000c), showed that ~ 41% of added virus were absorbed onto Dynal magnetic beads (M-280) coated with 12.5 µg of anti-HAV K3-2F2 monoclonal antibody per mg of beads. Similarly, 62% of virus were captured onto virosorb filters and 31.3 – 34.8% of virus were recovered when the positively charge virosorb filters were eluted with 1% beef extract, pH 9.5. However, the presence of beef extract inhibited detection of the virus by PCR techniques. Papafragkou et al (2008) observed ~50% adsorption of HAV to positively charged magnetic beads in 50 mM glycine 150 mM NaCl, pH 9.

2.3.3 Detection of Virus

Cell culture based methods

HAV requires an extensive adaptation period before it grows in cell culture, and once adapted becomes attenuated. HAV in cell culture rarely shows cytopathic effects or apparent host cell damage (Nainan et al. 2006). As wild type HAV show little visual effect on host cells in culture, detection and quantification of these virus in cell culture is dependent on immunological assays such as radioimmunofocus, radioimmunoassay and in situ hybridization (Nainan et al. 2006) and are rarely used. For this reason, laboratory based tests almost exclusively use the adapted variants of HAV HM-175 24A (ATCC # VR1402) propagated in fetal rhesus monkey cells (FRhK-4) (Mbithi et al. 1990; Bidawid et al. 2000c). The adapted cells have a shorter replication cycle, show a cytopathic effect (plaques) and produce a higher viral yield. However there is no information about how typical HM175 is of wild type virus.

PCR based methods

The basic steps involved in detection of HAV by molecular methods are (i) extraction of the RNA from the virus, (ii) conversion of the RNA to c-DNA by reverse transcriptase (iii) amplification of the c-DNA by PCR and (iv) detection of the PCR products.

Nucleic Acid Extraction and Detection

Extraction

A variety of techniques have been used to extract the RNA from HAV. These include the more time consuming extraction with reagents such as guanidinium thiocyanate-/phenol-chloroform. Most extractions are now performed with proprietary products (eg QIAGEN RNeasy, Trizol (Invitrogen Life Technologies), FTA cards (Whatman) QIAamp, Virus Nucleospin RNA kit (Macherey-Nagel GmbH & Co KG, Duren Germany). (Brassard et al. 2009) compared three different RNA extraction methods (QIAGEN, RNeasy; TRIzol,; and Flinders Technology Associated filter paper, FTA card, Whatman) with one and two step PCR reactions and concluded that QIAGEN extraction followed by one step RT-PCR increased the sensitivity of detection of HAV by 1-2 log₁₀ compared to the other methods (using primers to the 3C protease region of HAV and detection of PCR products on an ethidium bromide stained gel).

Costafreda et al. (2006) showed that the efficiency of extraction of the viral RNA was highly variable (0.1 – 100%), while the efficiency of detection of viral RNA (the RT-PCR process) was also variable (some samples as low as 1%) but generally > 75%. This variability seemed to be sample specific, and may reflect differences in the level of PCR inhibitors remaining in the samples.

RT- PCR

Various methods of reverse transcriptase PCR have been used for the detection of HAV RNA. These include one step and two step RT PCR, where the reverse transcriptase and PCR steps are carried out sequentially in the same reaction mix, or in separate reaction mixes respectively, nested RT-PCR and TaqMan RT-PCR. Most authors have found no advantage in using a two step RT-PCR over the one step method (Costafreda et al. 2006; Brassard et al. 2009). Several authors have indicated increase in sensitivity by the use of nested real time PCR using TaqMan probes (Costafreda et al. 2006; Hu and Arsov 2009). Hu and Arsov (2009) reported detection of 200 PFU with conventional PCR (detection on EtBr stained gels), 20 PFU with Real-time PCR quantitated with a TaqMan probe, and 0.2 PFU with nested real time PCR, where the products of the conventional PCR were amplified with primers internal to the initial primers and the products were detected with TaqMan probes.

PCR primers and specificity

As indicated above, numerous PCR primers have been used by various authors. For simple detection of HAV, the design of primers in regions of the genome where the nucleotide sequence is well conserved across the various genotypes provides detection of all genotypes. These regions include the 5' untranslated region of HAV (Costafreda et al. 2006), the VP1-VP3 capsid protein region (Deng et al. 1994; Bidawid et al. 2000c; Love et al. 2008) and the 3C protease region (Brassard et al. 2009).

Costafreda et al (Costafreda et al. 2006) aligned the known consensus sequence of virus from all human genotypes to identify the most conserved regions of the 5' untranslated region of the virus from which to design primers and probes for TaqMan RT-PCR. The forward and reverse primers chosen were HAV68 (nt 68-85) and HAV240 (nt 240-222) respectively and HAV150 (nt 168-149) was used as the probe for TaqMan RT-PCR. These probes did not detect 10 different picornaviruses, other enteric viruses (hepatitis E, group A rotavirus, Norovirus, Mamastrovirus) or Human adenovirus F. Similarly, probes to the VP1-VP3 region of HAV did not detect RNA from porcine gastroenteritis virus, bovine respiratory syncytial virus, canine distemper virus, bovine parainfluenza virus type 3 (PI3) or norovirus (Serracca et al. 2009).

(Endo et al. 2007a) identified regions of HAV that provided universal detection and genotypic analysis by aligning entire genomic sequences of 21 HAV isolates. These authors identified regions in the VP1-2B area and the 3C/3D junction, where variable sequences were surrounded by conserved regions that provided regions where PCR primers could be designed. Use of these primers in RT-PCR allows amplification and detection of PCR amplicons, and sequencing of these amplicons provides information on the phylogeny of the isolates.

Sensitivity of the RT-PCR and limits of detection

It is difficult to compare the sensitivity and limits of detection of the various RT-PCR based detection methods for HAV because of the variety of elution, concentration, RNA extraction, and RT-PCR methods employed (Table 2). None the less, in studies where direct comparisons have been made, it does appear that the used of nested PCR, associated with real time PCR detection provides greater sensitivity than conventional RT-PCR (Costafreda et al. 2006; Love et al. 2008; Hu and Arsov 2009). (Costafreda et al. 2006) found the detection limits for RT-PCR using TaqMan detection to be 10 ss RNA molecules, 1 viral RNA molecule and 0.05 infectious virus per reaction. (Deng et al. 1994) estimated that the ratio of HAV genome copies (RNA containing viruses) to PFU was 79, while (Costafreda et al. 2006) used a value of 60 in their calculations.

Costafreda et al. (2006) also highlighted the variability of several steps in the current methods, which seemed to be sample specific. The efficiency of RNA extraction from HAV in shell fish was determined to be ~ 0.1% and in individual stool and serum samples the efficiency of extraction varied between 12 and 100%. Through the use of mengovirus and control ssRNA as internal standards, Costafreda et al. (2006) estimated the efficiency of recovery at each step in the process and determined that the level of HAV in shellfish implicated in an HAV outbreak at between 7.5×10^3 and 7.9×10^5 HAV genomes / g digestive tissue. The lower level was based on the actual detection of 4.4 genome copies in the sample subjected to RT-PCR analysis.

On the basis of comparison to Tissue Culture Infective Dose₅₀ (TCID₅₀) Serracca (2009) determined that the RT PCR technique (extraction, from mussels, PEG concentration, RNA extraction and PCR amplification and detection) was able to reliably detect HAV contaminations $\geq 1 \times 10^4$ TCID₅₀. whereas $\geq 1 \times 10^1$ TCID₅₀ particles

were detected from supernatants of HAV infected FRhK4 cell cultures. These data are again consistent with a recovery of 0.1% of the HAV added to the mussels. The losses could occur in the mussel extraction and virus concentration steps, although the presence of inhibitory compounds that were co-concentrated with the virus can not be excluded.

These data indicate that sensitive RT-PCR techniques are available for the detection of HAV in foodstuffs. The major factors that currently limit the sensitivity of the technique appear to be the extraction and concentration of the virus from the foodstuff and free from PCR inhibitors. While the ratio of viral particles to infectious particles (as determined by cell culture assays of an attenuated strain) has been estimated to between 60 and 80 (Deng et al. 1994; Costafreda et al. 2006), the low efficiency of recovery of viral RNA from foodstuffs reported by some authors (0.1%) (Costafreda et al. 2006; Serracca et al. 2009) would suggest that detection of viral RNA by the current techniques would most likely indicate the presence of infectious viral particles in the food. From this perspective, the stability of viral RNA released into the environment from defective virus particles should also be considered. Data on this subject appears to be scarce. Tsai et al (Tsai et al. 1995) studied the degradation of RNA isolated from poliovirus in filtered (0.2 µm pore size) and unfiltered sea water at 23 °C and 4 °C. These authors found that the RNA was undetectable (<600 fg RNA) in unfiltered sea water after 2 days at both temperatures, while the RNA was detected after 21 days but not 28 days in the filtered seawater. The authors concluded that the relatively short life time of the RNA in this environmental sample meant that the RT-PCR procedure was mainly detecting RNA from viral particles and not naked viral RNA.

Potential use of surrogates for HAV

The presence of bacterial indicators in sewage have not correlated with the presence of HAV (Villar et al. 2007) indicating that bacteria may not be good predictors for HAV in sewage. The use of various surrogates (which will behave the same as HAV under the conditions being tested but are easier to detect and enumerate) has been investigated for determining the survival and inactivation of HAV under various conditions. In some cases the bacteriophage MS2 was found to behave like HAV (Casteel et al. 2008), while other reports suggest it is not an appropriate surrogate for HAV (Blanc and Nasser 1996; Nuanualsuwan et al. 2002).

2.4 Survival of HAV on fresh produce

2.4.1 Impact of chilling and freezing on HAV

The results of most studies indicate there is little effect of chilling and freezing on the numbers of HAV on fresh produce (Table 3). Storing produce at chilled temperatures tends to favour survival of HAV on produce when compared to storage at room temperature (Bidawid et al. 2001) and in many cases, deterioration of the produce is likely to occur before the virus has completely died off (Baert et al. 2009). HAV

survived on spinach leaves stored under chilled conditions for more than 4 weeks with just over a 1 log₁₀ decrease in numbers (Shieh et al. 2009). The D value (time taken for a 1 log₁₀ reduction in virus numbers) on spinach leaves stored at 5.4 °C was calculated to be 28.6 days (Shieh et al. 2009). Survival is greatly affected by the type of produce which is probably related to the texture and antimicrobial properties of the surface of the produce. For example, HAV was detected for longer on lettuce (9 days) during chilled storage than on fennel (7 days) or carrot (4 days) (Croci et al. 2002). The longer survival time on lettuce was thought to be due to the wrinkled texture of the leaves while the shorter survival time on carrot was attributed to potential antimicrobial substances (Croci et al. 2002).

Freezing also has little impact on the reducing numbers of HAV in berries (blueberries, raspberries, strawberries) and herbs (basil and parsley) with less than 1 log₁₀ reduction over 90 days of frozen storage (Butot et al. 2008). Freeze drying berries and herbs resulted in less than 1 log₁₀ reduction in HAV as determined by real time reverse transcriptase PCR, but inactivation of virus measured using tissue culture (TCID₅₀ counts) was larger (between 1.2 and 2.4 log₁₀) (Butot et al. 2009). The differences observed in the inactivation of viruses as determined using the different methods was significant and highlights the difficulties in comparing results of inactivation studies which use different methods.

Table 3. Survival of hepatitis A virus on fresh produce during storage

Strain of HAV	Mode of Inoculation	Method of detection	Produce Type	Temp (°C)	Storage Time ^a	Reduction (log ₁₀)	Unit ^c	Comments	Reference
HM-175	Add virus suspension to surface of leaf and spread across a known area, allow to dry for 10-20 min	Tissue culture - plaque assay on FRhK-4 cells	Romaine Lettuce (pieces)	4 22	12 d 12 d	0.1 (48% survival) 4.4 (0.01% survival)	PFU/ml PFU/ml	Storage under modified atmospheres (30:70; 50:50; 70:30 CO ₂ :N ₂ and 100% CO ₂) was also determined but there was very limited reduction in virus numbers (mean of 64% survival at 4 °C and 11% at room temperature)	(Bidawid et al. 2001)
Italian clinical strain	Produce immersed in virus suspension for 20 min then drained and allowed to dry	Used both Reverse Transcriptase (RT) - nested PCR and tissue culture Infective on PCR positive samples for	Lettuce Fennel Carrot	4	9 d 7 d ^b 4 d ^b	2 >3.3 >2.4	TCID ₅₀ /ml		(Croci et al. 2002)

Strain of HAV	Mode of Inoculation	Method of detection	Produce Type	Temp (°C)	Storage Time ^a	Reduction (log ₁₀)	Unit ^c	Comments	Reference
		quantitation							
HM-175	Add virus suspension to surface of plant material	Real time RT-PCR and tissue culture	Blueberries Raspberries Strawberries Basil Parsley	frozen	2 d	0.4 0 0.1 0.1	TCID ₅₀		(Butot et al. 2008)
HM-175	Add virus suspension to surface of leaf	Plaque assay on tissue culture cell line	Spinach	5.4	1 d 6 wk	0.2 1.9	PFU/10 ml		(Shieh et al. 2009)

^a d – days, wk – weeks

^b not detected after this time (samples stored for 9 days).

^c PFU – plaque forming units; TCID₅₀ - 50% tissue culture infective dose

2.4.2 Effect of modified atmosphere packaging

There have been limited studies investigating the survival of HAV on produce stored under modified atmospheres but what has been published suggests there is little impact on HAV. Survival of HAV on lettuce packed under various modified atmospheres (100% CO₂ and the following CO₂:N₂ mixtures - 30:70; 50:50; 70:30) was followed for 12 days (Bidawid et al. 2001). Both log₁₀ pfu/ml and % survival was determined. There was less than 1 log₁₀ reduction and no significant differences in percent survival when inoculated lettuce was stored at 4 °C regardless of the atmospheric conditions. When inoculated lettuce was stored at room temperature in a Petri dish for 12 days, only 0.01% of inoculated HAV survived (~4.4 log₁₀ reduction in count). The percent survival of HAV in modified atmosphere packaged (MAP) lettuce was significantly reduced (from 5.3 to 8.6% survival) in all treatments except 70% CO₂, where 48% of virus survived after 12 days at room temperature. Survival of HAV was generally lower at room temperature (22 °C) than at 4 °C and was not affected by MAP conditions at the higher temperature.

2.5 Survival on inanimate surfaces

HAV is capable of surviving on many different surfaces which may be used in food manufacture. The virus can quickly attach to a range of surfaces such as stainless steel, copper, polythene and polyvinyl chloride (Kukavica-Ibrulj et al. 2004). Once attached to a surface, HAV can be difficult to remove and can survive for extended periods of time. Factors such as the material the virus is present in when contacting a surface, the type of surface, the temperature and the relative humidity (RH) all impact on viral survival on surfaces (Abad et al. 1994a). Drying of the virus (suspended in either a phosphate buffer or 20% human faeces) onto a range of different surfaces using a flow cabinet at room temperature for 3 – 5 h resulted in less than 2 log₁₀ reduction (Abad et al. 1994a). Once dried onto surfaces such as aluminium and china, viral numbers decreased by less than 2 log₁₀ over 60 days storage at either 4 or 20 °C (Abad et al. 1994a). There was no loss of HAV infectivity after being air dried onto

stainless steel for > 4 h in either plasma (90% plasma) or laboratory culture medium (Terpstra et al. 2007). Storage of the contaminated stainless steel at room temperature resulted in less than 1 log₁₀ reduction in HAV after 7 days, and virus populations were still present after 28 days at levels between 2 and 3 log₁₀ (Terpstra et al. 2007).

HAV suspended in faeces and placed onto stainless steel survived longer at lower RH and chilled temperatures (half life of > 7 days at 25% RH and 5 °C) than at higher RH and higher temperatures (about 2 h at 95% RH and 35 °C) (Mbithi et al. 1991). Though in another study the survival of HAV on various surfaces was found to be greater under conditions of high RH (Abad et al. 1994a).

2.6 Survival and transfer of HAV in the environment

Human enteric viruses can enter the environment in which plants are grown through the use of human biosolids for amending soil for agricultural use (World Health Organization 2008). The application of biosolids to land for beneficial purposes is increasing worldwide in a bid to reduce environmental contamination and under certain conditions pathogens present in biosolids may have the potential to contaminate surface waters, groundwater and soils and to enter the food chain (Sidhu and Toze 2009). HAV has been shown to survive in dried human faeces stored at 25 °C and 42% RH for 30 days (McCausland et al 1982). Once HAV enters the environment in which crops are grown, it is possible that produce may become contaminated. The survival of HAV inoculated onto the fruits of plants (cantaloupe, lettuce and bell peppers) grown in a controlled environment chamber was followed for 14 days. Virus survival was significantly longer on cantaloupe than on lettuce or bell peppers and survival was longer under dryer conditions (low RH of 45-48%) than under high RH (86-90%) (Stine et al. 2005b).

HAV may also enter the environment in which plants are grown via the use of contaminated water which may be used for irrigation or during further processing such as washes. A study by Stine et al. (2005a) determined the transfer of a surrogate for HAV (a coliphage called PRD1) onto the surfaces of cantaloupe, lettuce and bell peppers using furrow and subsurface drip irrigation in field experiments. Transfer rates varied based on the type of irrigation used (lower transfer rates occurred when using subsurface drip irrigation) and the type of produce (highest transfer rates occurred on cantaloupe, the lowest on bell peppers). The difference in transfer rates was attributed to the physical properties of the produce such as surface texture and the location of the produce in relation to the irrigation water (e.g. whether the edible portion of the plant is in direct contact with the soil or elevated off the ground). Using the data generated from these experiments a risk assessment was conducted to determine the concentration of HAV in irrigation water that would result in an annual risk of 1:10000 from consumption of irrigated produce (Stine et al. 2005a). The greatest risk was from furrow irrigated produce harvested and consumed the day after the last irrigation event and was calculated to be 2.5×10^{-5} and 7.3×10^{-3} most probable number (MPN) per 100 ml of irrigation water for lettuce and cantaloupe respectively. The risks for an annual infection rate of 1:10000 from lettuce and cantaloupe furrow irrigated 14 days

prior to harvest were 1.2×10^{-3} and 9.9×10^{-3} MPN/100ml of irrigation water respectively (Stine et al. 2005a). The contamination of bell peppers by irrigation water was calculated to be below the limit of detection of the experiments (Stine et al. 2005a). These experiments suggest the risk of infection from consuming fresh produce contaminated via irrigation water is low although the potential is there if the concentration of virus is high.

There is limited information on the survival of HAV in soils, probably due to the difficulties involved in developing suitable extraction protocols (Rzezutka and Cook 2004). The information that is available suggests that the survival of HAV in soils is affected by the temperature, moisture content (Gerba et al. 2002) and soil type (Sobsey et al. 1995). Reduction of HAV applied in either groundwater or primary sewage effluent to columns of soils of different compositions was greater in clay loam soils (> 2.1 and $> 3.6 \log_{10}$ respectively) than in sandy soils (1.5 and $1 \log_{10}$ respectively). These experiments were conducted at both 5 and 25 °C and reduction (as measured by retention of the virus by soil columns) of HAV was higher at 25 °C although mean reductions differed only by $0.6 \log_{10}$ (Sobsey et al. 1995). HAV numbers were unaffected after 20 days in soils saturated with secondary/tertiary treated wastewater under ambient conditions (Blanc and Nasser 1996). These experiments indicate that HAV can survive in soils for reasonable periods of time.

In addition to potential for contamination of crops in fields through contaminated soil and water, a lot of emphasis has been placed on the role food handlers (including those preparing foods and those who harvest crops in the field) have in contamination of produce (Koopmans and Duizer 2004). The importance of this route of infection is supported through several studies that have shown HAV can be transferred from fingers to food contact surfaces and fresh produce in short periods of time (10 s of contact). Faecally suspended HAV applied to the hands of human volunteers resulted in high numbers of viruses being detected immediately after application, followed by a rapid decline of about 68% in numbers after the first 60 min, then a slower decline after that time with between 16 and 30% of initial virus numbers still detected on fingerpads after 4 h (Mbithi et al. 1992). HAV could be transferred from fingerpads to stainless steel discs and the amount of virus transferred increased if greater pressure and friction were applied. Pressing clean fingerpads against contaminated stainless steel surfaces also resulted in transfer of the virus to fingerpads but the numbers transferred declined the longer the virus was left on the surface. There was 22% transfer of viral numbers if contact occurred 20 min after the virus was inoculated onto the surface while no measureable transfer occurred if the virus was inoculated onto the surface 4 h prior to contact even though virus could still be recovered from the surface after 4 h. Transfer of HAV also occurred from person to person as measured through contact between the fingerpad of one volunteer to another (Mbithi et al. 1992). Not only can HAV be transferred between inanimate surfaces and fingers and vice versa, but transfer to produce has also been demonstrated. Further experiments using human volunteers found up to 9.2% of virus could be transferred from fingerpads to pieces of fresh lettuce after 10 s of contact (Bidawid et al. 2000a). The information described above highlights the importance of human hands and contaminated surfaces in the transfer of HAV.

Transfer of HAV from fingerpads to lettuce could be reduced by 30 fold through the application of topical agents (non-medicated and medicated soap) and hand gels containing ethanol and by rinsing fingerpads with larger volumes of water (15 ml vs 1ml) with some pressure (Bidawid et al. 2000a). Investigation of different agents used for hand washing to reduce HAV on hands and fingerpads also found that washing in warm water alone could reduce HAV numbers by 79.7% (Mbithi et al. 1993). Washing with a range of different agents (including alcohol, triclosan and chlorhexidine gluconate based agents), reduced HAV by between 77 and 92% on fingerpads and 81 and 94% when whole hands were washed. The transfer of HAV between fingerpads and stainless steel discs was reduced after hands were treated with hand washing agents when compared to washing only with water though infectious HAV was still detected on the stainless steel after treatment with 7 out of 10 agents (Mbithi et al. 1993). This suggests that hand washing can reduce levels of HAV and limit subsequent transfer to surfaces but hand washing alone may not be enough to interrupt viral transfer. Investigation into the development of effective and safe formulations for inactivation of HAV on hands, on food and food contact surfaces is necessary to assist in limiting the spread of HAV via foods (Sattar et al. 2000; Sattar et al. 2002). Maintaining strict personal hygiene and educating food handlers to improve their knowledge about the control of food borne disease will help improve the safety of foods in general (Angelillo et al. 2000).

2.7 Survival and inactivation in water

Outbreaks of HAV have been linked to its presence in surface waters which have been used for drinking and recreational uses. Water may act as a source of contamination for foods irrigated with waters containing HAV. There is limited available data to determine the importance of contaminated irrigation water in the spread of food borne viral diseases though it remains a likely mechanism of disease transmission (Sair et al. 2002). Several publications indicate that HAV can survive in both fresh and marine water for extended periods of time. When a range of results from various publications were evaluated, HAV was found to have a longer inactivation rate in groundwater than other virus or bacterial pathogens with an estimated mean inactivation rate of 0.03 \log_{10} per day (John and Rose 2005). Temperature had a limited effect on HAV with a mean inactivation rate at 0 – 10 °C of 0.02 \log_{10} per day and at 20 – 30 °C of 0.04 \log_{10} per day (John and Rose 2005). Lower temperatures and the presence of sediment in waters appear to enhance survival of HAV (Bosch 1995). An early report on the survival of HAV in mineral water found the virus survived for 300 days at 4 °C with an insignificant reduction in infectivity and was still detected in water stored at 22 °C after the same time period (Biziagos et al. 1988). HAV levels decreased by 1.6 \log_{10} when stored in tap water for 55 days at 4 °C with a predicted time for 99% inactivation of 56 days (Enriquez et al. 1995). The time for inactivation decreased with increasing temperature with 27 days predicted for 99% inactivation of HAV in tap water stored at 23 °C (Enriquez et al. 1995). In seawater, a 4 \log_{10} reduction of HAV was calculated to take around 49.8 days at 20 °C (Callahan et al. 1995).

Chlorination has been shown to be one of the most effective treatments for inactivation of HAV in fresh water (Bosch 1995). The contact time and concentration of chlorine are important for inactivation of the virus. Early research from the 1980s indicated that inactivation of HAV in drinking water was obtained with a free chlorine residual of 1-2 mg/l with a contact time of 1 – 2 h at a pH <8 (Grabow et al. 1983). Application of 0.8 to 1.2 mg/l free chlorine to water was not sufficient to inactivate HAV and 90.0 and 99.9% inactivation only occurred after treatment with chlorine concentrations of 1.4 and 6.4 mg/l and exposure for 20 min (Hedachin et al. 1993). Treatments such as coagulation, settling, filtration and disinfection have been found to be effective for inactivation of HAV in water (Chalapathi Rao et al. 1988; Nasser 1994). The addition of other antimicrobial compounds such as silver and copper ions did not result in inactivation of HAV in water (Abad et al. 1994b).

HAV has been detected in spring water, well water, rivers and dam waters in countries such as Thailand, Italy, South Africa and the USA (Bloch et al. 1990; Bosch et al. 1991; Morace et al. 1993; Pipat et al. 1994; Borchardt et al. 2003; Kittigul et al. 2006; Venter et al. 2007). Outbreaks have been associated with the use of such waters for recreational purposes and for drinking and irrigation. Water used for watering gardens has also been implicated as the cause of a HAV outbreak (Barrimah et al. 1999). Contamination of water is most likely to occur from sewage effluents, either untreated or treated. Commonly used sewage treatment may not always be adequate for removing or inactivating food borne viruses (Carducci et al. 2009). A study investigating the presence of HAV in raw and treated sewage samples from an activated sludge plant servicing Rio de Janeiro, Brazil, detected HAV in 24 of 25 treated sewage samples using real time PCR (Villar et al. 2007). In this study, faecal coliform populations were reduced by 99.9% while HAV numbers (based on real time PCR) were only reduced by 42% during the treatment process (Villar et al. 2007). The use of ultraviolet radiation (UV) for inactivation of HAV has been tested in buffer, a dose of 36.5 mW s/cm² was required to inactivate HAV by one log (Nuanualsuwan et al. 2002). The application of this technology is thought to be most appropriate for treatment of water and wastewater. Household water treatment systems using activated carbon filters and UV light have been found to effectively remove 99.99% of enteric viruses (Abbaszadegan et al. 1997).

2.8 Inactivation of HAV on produce

2.8.1 Decontamination by washing and disinfection

There is little information on levels of HAV on naturally contaminated produce (Butot et al. 2009) so the level of viral inactivation required is not known. The impact of washing for reducing levels of HAV on produce is highly variable and its effectiveness is dependant on many factors which are discussed below in further detail. The impact of treatments is dependant on the type of produce being washed or sanitised and as very little work has been conducted looking at reducing levels of HAV on tomatoes, the effectiveness of such treatments for use on tomatoes is unknown.

Washing in water alone (without the addition of any sanitisers) can lead to slight reductions of HAV on certain types of produce. Washing of lettuce, fennel and carrots with potable water for 5 min resulted in decreases in HAV numbers up to approximately 1 log₁₀ when compared to unwashed vegetables (Croci et al. 2002). Washing blueberries, raspberries, strawberries, basil and parsley for 30 s with tap water and warm water (43 °C) resulted in between 0.03 and 1.1 log₁₀ reductions of HAV depending on the product (the greatest reduction was observed on basil, the least on parsley). There were no significant differences observed in viral inactivation between the tap water and warm water washes used on the same product (Butot et al. 2008).

The most studied sanitisers (disinfectants) for inactivating HAV on produce are those in which chlorine is an active ingredient. These have been found to be the most effective although concentration, contact time and temperature of treatment are all important factors for appropriate inactivation of HAV (Jean et al. 2003; Bigliardi and Sansebastiano 2006). Washing berries and herbs with 200 ppm free chlorine reduced HAV levels significantly (when compared to washing in water alone) on blueberries (2.4 log₁₀ reduction), strawberries (1.8 log₁₀ reduction) and basil (2.4 log₁₀ reduction), but not on raspberries (0.6 log₁₀ reduction) or parsley (1.4 log₁₀ reduction) (Butot et al. 2008). Further experiments were conducted on inactivation of HAV on raspberries and parsley using chlorine dioxide, washing for one minute at levels up to 50 ppm were ineffective. Washing raspberries and parsley in 10 ppm chlorine dioxide for 10 min reduced HAV levels between 0.8 and 1.8 log₁₀ respectively (Butot et al. 2008). Inactivation of HAV using 10 ppm free chlorine on cherry tomatoes (calyxes removed) resulted in undetectable virus levels (> 2.3 log₁₀ reduction) after 5 min contact time, while at 20 ppm free chlorine it took 3 min to achieve the same effect (Casteel et al. 2008). Inactivation of HAV on lettuce resulted in undetectable levels of virus after 5 min contact time at both 10 ppm and 20 ppm free chlorine. Inactivation of HAV on strawberries was more difficult with only a 1.5 log₁₀ and 1.2 log₁₀ reduction in numbers of virus after 5 min at 10 ppm and 20 ppm free chlorine respectively. A contact time of 10 min resulted in ≤ 2.3 log₁₀ reduction of HAV on strawberries and the level of inactivation of virus was only slightly improved by treatment with 200 ppm free chlorine which resulted in 2.6 log₁₀ reduction after 5 min contact (Casteel et al. 2008). Cherry tomatoes were found to have a lower chlorine demand (> 87% of free chlorine remaining after 10 min exposure to 10 or 20 ppm free chlorine) than lettuce, which was considered to have an intermediate chlorine demand, and strawberries which had the highest demand for free chlorine. The chlorine demand of the produce was thought to impact on the ability of chlorine to inactivate the virus (Casteel et al. 2008). A summary of the effect of some disinfectants on the inactivation of HAV on fresh produce are shown in Table 4.

The use of other disinfectants for inactivation of HAV has met with limited success with most experiments conducted only in suspension or on inanimate surfaces and not on produce. One laboratory investigation on the effect of chlorine dioxide at 2 ppm with a contact time of 30 s on strawberries contaminated with HAV reduced levels by less than 70% (Mariam and Cliver 2000). Sodium hypochlorite was found to be more effective at inactivating HAV on surfaces (such as aluminium, stainless steel, copper, polyvinyl chloride and high density polyethylene) than other disinfectants containing

quaternary ammonium, glutaraldehyde, sulfonic and phosphoric acids, although the concentration of sodium hypochlorite used in these experiments was high (between 200 and 3000 ppm) (Jean et al. 2003). Treatment at a temperature of 22 °C provided greater inactivation of HAV than at 4 °C for the same contact time and concentration of disinfectant (Jean et al. 2003). Bigliardi and Sansebastiano (2006) studied the inactivation kinetics of peracetic acid, chlorine and chlorine dioxide on HAV in suspension (not on produce) using a combination of PCR detection of viral RNA and tissue culture. Chlorine based disinfectants were found to be more effective at inactivating HAV than peracetic acid under the laboratory conditions used. The mean 99% inactivation time of peracetic acid at 480 and 640 mg/l was 52 and 36 min respectively, while for hypochlorous acid the mean 99% inactivation times were 35 and 12 min for 0.4 and 1 mg/l respectively (Bigliardi and Sansebastiano 2006). The mean 99% inactivation times of HAV when treated with 0.4 and 0.6 mg/l of chlorine dioxide were 4 and 2 min respectively (Bigliardi and Sansebastiano 2006). The concentrations of disinfectants used in these experiments were considered to be those most commonly used in practice. Further experiments conducted with chlorine dioxide showed concentrations greater than 0.6 mg/l resulted in fast inactivation times of HAV in laboratory experiments (Zoni et al. 2007). Reductions of HAV dried onto glass coverslips and then treated with a quaternary ammonium compound (QAC) for 10 min at between 1 and 10 times the recommended concentration were limited (between 0.4 and 0.7 log₁₀) (Solomon et al. 2009). The effect of an oxidative disinfectant (Virkon® - active ingredient is potassium peroxomonosulphate) on HAV dried onto glass coverslips with a contact time of 10 min was greatest at 1% concentration (> 3.2 log₁₀) but limited reductions occurred at lower concentrations (Solomon et al. 2009). A study by Mbithi et al. (1990) reported sodium hypochlorite (5000 ppm free chlorine), quaternary ammonium with 23% hydrochloric acid and 2% glutaraldehyde were the most effective disinfectants for inactivation of HAV (mixed with faeces) on stainless steel with > 4 log₁₀ reductions in infectivity. Other disinfectants including peracetic acid, phosphoric acid, acetic acid, citric acid, phenolics, iodine based products and alcohols resulted in < 1 log₁₀ decreases (Mbithi et al. 1990). Disinfectants containing free chlorine appear to be the most effective for inactivation of HAV on inanimate surfaces as well as on produce.

Table 4. Effect of different disinfectant treatments on hepatitis A virus on produce

Strain of HAV	Mode of Inoculation	Method of detection	Produce Type	Disinfectant	Exposure time	Reduction (log ₁₀)	Unit ^a	Comments	Reference
HM-175	Add virus suspension to surface of plant material	Tissue culture	Cherry tomatoes	10 ppm free chlorine	1 min	1.3	PFU/ml	Other contact times of 0.5 and 3 min were also measured	(Casteel et al. 2008)
					5 min	>2.3			
					10 min	>2.3			
				20 ppm free chlorine	1 min	1.4			
					5 min	>2.4			
					10 min	>2.4			

LITERATURE REVIEW: HEPATITIS A VIRUS SURVIVAL AND CONTROL

Strain of HAV	Mode of Inoculation	Method of detection	Produce Type	Disinfectant	Exposure time	Reduction (log ₁₀)	Unit ^a	Comments	Reference
HM-175	Add virus suspension to surface of plant material	Tissue culture	Strawberries	10 ppm free chlorine	1 min	1.4	PFU/ml	Other contact times of 0.5 and 3 min were also measured	(Casteel et al. 2008)
					5 min	1.5			
					10 min	2.2			
				20 ppm free chlorine	1 min	0.7			
					5 min	1.2			
					10 min	2.3			
HM-175	Add virus suspension to surface of plant material	Tissue culture	Lettuce	10 ppm free chlorine	1 min	1.3	PFU/ml	Other contact times of 0.5 and 3 min were also measured	(Casteel et al. 2008)
					5 min	>2.3			
					10 min	>2.3			
				20 ppm free chlorine	1 min	1			
					5 min	>1.7			
					10 min	>1.7			
HM-175	Add virus to wound left after removing cap	Tissue culture	Strawberries	2 mg/l chlorine dioxide	30 min	< 1 (69% reduction)	PFU	Maximum reductions after 5 min of draining after neutralizing	(Mariam and Cliver 2000)
				4 mg/l chlorine dioxide	30 min	< 1 (81 % reduction)			

^a PFU – plaque forming units

The use of ozone for inactivation of HAV has also been investigated and has shown some promise for application in water treatment, although its application for decontaminating produce, food contact surfaces and equipment is yet to be realised (Khadre et al. 2001). Complete inactivation (5 log₁₀ reduction) of HAV in buffer at ozone concentrations of 1 mg/l or higher took less than 1 min and were not affected by the pH of the buffer system used (Vaughn et al. 1990). HAV inactivation in water was found to be greater and faster at the lower temperature of 10 °C, compared to 20 °C, with complete and almost instantaneous inactivation (TCID₅₀) occurring at a concentration of 0.27 mg/l ozone at 10 °C (Herbold et al. 1989). At concentrations of 2 and 0.4 mg/l ozone, HAV suspended in phosphate buffer solution was completely inactivated within 5 s (Hall and Sobsey 1993). Hydrogen peroxide at 1mg/l inactivated 95% of HAV under the same experimental conditions (Hall and Sobsey 1993).

Treatment of HAV air dried onto stainless steel coupons with 0.1N sodium hydroxide resulted in 3-3.5 log₁₀ reduction after 10 min (Terpstra et al. 2007). The use of 0.1% hypochlorite solution resulted in greater inactivation of HAV under the same conditions (> 4 log₁₀ reduction). The impact of these disinfectants on the dried HAV was affected by the type of material in which the virus was dried, with the higher protein containing material (plasma) providing greater protection from the disinfectant than culture media (Terpstra et al. 2007). A similar observation was made on the survival of HAV on spinach leaves where viral infectivity was preserved in the presence of serum (Shieh et al. 2009).

Laboratory experiments conducted on virus suspended in buffers have tried to understand the mechanisms of various inactivation treatments. The target for chlorine inactivation of HAV is thought to involve the nucleic acid (specifically the 5' nontranslated region which is involved with the replication of the virus), rather than the protein capsid of the virus (Li et al. 2002). While others have suggested activity of chlorine works on both the protein coat and the RNA (Nuanualsuwan and Cliver 2003).

The results of the experiments described above indicate that disinfection can reduce levels of HAV on produce by more than 2.4 log₁₀ and to greater degrees on other surfaces, but all these experiments were conducted under laboratory conditions and it is not clear how effective the same concentrations and contact times would be in an industrial setting. The effectiveness of washing of produce with water and various sanitisers and disinfectants for removal or inactivation of HAV is dependant on the type of produce, the sanitiser or disinfectant used, the concentration and contact time. It appears from the literature discussed above that free chlorine based disinfectants appear to be the most effective at reducing levels of HAV on fresh produce. Variation in the ability of chlorine based disinfectants to reduce HAV on produce is likely to be affected by the demand for free chlorine by different product types. Disinfection procedures need to be carefully monitored to ensure appropriate levels and contact times are maintained. The impact of using disinfectants on produce in relation to maintaining the desired qualities of the product also needs to be considered. In general, washing in any form appears to result in some slight decrease of HAV numbers.

2.8.2 Effect of heat treatments on HAV

Most publications dealing with heat treatment for inactivation of HAV have focussed on foods that are heated as part of processing (such as milk) or may be cooked prior to consumption (such as shellfish). There are very few publications describing the impact of heating for reducing HAV levels on fresh produce as these foods are likely to be consumed without any heat treatments. Heating of freeze dried berries (blueberries, blackberries, raspberries and strawberries) for 20 min at 80 °C in an oven reduced HAV levels by less than 2 log₁₀ (Butot et al. 2009). Greater reductions were observed at higher temperatures such as 100 and 120 °C with complete inactivation of virus infectivity occurring on all berries treated at 120 °C (as determined by tissue culture detection techniques) but viral RNA was still detected on strawberries (as determined using real time RT-PCR) (Butot et al. 2009). Blanching herbs for 2.5 min at 95 °C was

found to reduce HAV levels on basil, mint and chives by $> 3 \log_{10}$ and on parsley by $> 2.4 \log_{10}$ (Butot et al. 2009).

The impact of heat on HAV inactivation is influenced by many factors including the fat and sugar contents of foods. Investigation of heat inactivation of HAV in dairy products found the time required for inactivation increases in products with higher fat content suggesting that fat plays a protective role and increases the heat stability of HAV (Bidawid et al. 2000d). Higher sugar contents were found to be protective for HAV during heating while lower pH was found to assist viral inactivation in synthetic media designed to mimic strawberry mashes. The calcium concentration had no impact on viral inactivation from heat (Deboosere et al. 2004). D values (time of heat treatment to obtain a $1 \log_{10}$ reduction in virus) at 85 °C for synthetic media at 28, 40 and 52 °Brix (a measure of the concentration of soluble solids, mostly sugars) were 0.8, 1.9 and 6.3 min respectively. At pH values of 3.3, 3.8 and 4.3, D values at 85 °C were 1.52, 1.88 and 2.87 min respectively (Deboosere et al. 2004). The D and Z (temperature increase required to reduce the D value 10 fold) values for both synthetic media and a fruit product (prepared from mashed strawberries) were determined and are shown in Table 5 (Deboosere et al. 2004). Additional studies are required to validate the thermal inactivation of HAV before models can be developed and applied in industry (Deboosere et al. 2004). An earlier study of heating for inactivation of HAV in strawberry puree recorded a 99.98% reduction at 72 °C for 30 s (Mariam and Cliver 2000).

Table 5. D and Z values for inactivation of hepatitis A virus in synthetic media or fruit-based products as a function of the sucrose concentration (from Deboosere et al. 2004)

Material	Sucrose concentration (°Brix) ^a	D value ^b (min) at different temperatures			Z value ^c (°C)
		80 °C	85 °C	90 °C	
Synthetic media	28	1.73	0.80	0.22	11.26
	52	12.22	6.28	2.87	15.87
Fruit products	28	1.22	0.96	0.32	21.41
	52	8.94	4.98	3.00	21.10

^a °Brix is a measure of the concentration of soluble solids, mostly sugars

^b D value – time required to obtain a $1 \log_{10}$ reduction in virus titre

^c Z value – the increase in temperature required to decrease the D value 10 fold

Other variables in different food products also impact on the heat inactivation of HAV. Inactivation of HAV at 80 °C took more than 15 min in shellfish homogenate compared to only 3 min in suspension (Crocì et al. 1999). Adding different ingredients to mussels (such as butter or tomato sauce) also impacted on the inactivation of HAV from heating. Complete inactivation of HAV occurred when mussels were cooked (immersed) in a boiling tomato sauce after 8 min but not when grilled with butter at a temperature of 250 °C for 5 min (Crocì et al. 2005).

The strain of HAV used in heat inactivation studies can also impact on the results. Generally, the strain HM-175 is used in most experimental studies as it produces a cytopathic effect in tissue culture assays. A recent study on the heat inactivation of various strains of HAV (though not HM-175) in human serum albumin found considerable variation in their resistance to heating at 60 °C for 10 h as the strains varied in log₁₀ reductions from 3.1 to 5.1 (Shimasaki et al. 2009). A summary of the information on heating of produce for inactivation of HAV on produce is shown in Table 6.

Table 6. Effect of different heat treatments on hepatitis A virus on produce and impact of viral strain

Strain of HAV	Mode of Inoculation	Method of detection	Produce Type	Temp (°C)	Exposure time	Reduction (log ₁₀)	Unit ^a	Comments	Reference	
HM-175	Add virus suspension to surface of plant material	Real time RT-PCR and tissue culture	Basil	95	2.5 min	> 3	TCID ₅₀	Heat treatment was considered as "blanching" and heat was applied as steam	(Butot et al. 2009)	
				75		1.9				
			Chives	95	> 3					
				75	> 3					
			Mint	95	>3					
				75	1.7					
			Parsley	95	>2.4					
				75	2.1					
HM-175	Add virus to wound left after removing cap	Tissue culture	Strawberry puree (4 parts strawberry and 1 part sugar)	71.7	15 s	2-3 (99.8% reduction)	PFU	pH of 3.8	(Mariam and Cliver 2000)	
						30 s				3-4 (99.98% reduction)
						60 s				> 4 ^b
					90.6	15 – 60 s				> 4 ^b
					60	10 h				3.1
KRM238	Virus mixed with of human serum albumin	Tissue culture assay with immunofocus staining				4.7	Infective dose (focus forming units)	(Shimasaki et al. 2009)		
KRM003						5.1				
KRM031						3.3				
TKM005										

^a TCID₅₀ - 50% tissue culture infective dose, PFU – plaque forming units, Infective dose – HAV foci detected on tissue culture cells after immunological staining

^b not detected

2.8.3 Processing technologies

As with heat treating produce, very few publications have investigated the impact of other processing technologies on HAV inactivation specifically on produce. Although some processing technologies can reduce HAV levels their impact on the organoleptic and structural properties of fresh produce and their application on a commercial scale still requires further investigation. The effectiveness of various processing technologies on HAV varies with the type of food being treated. High pressure processing (HPP) is the most studied technology for reducing levels of HAV and is capable of complete inactivation of the virus in tissue culture medium when treated at pressures above 450 MPa for 5 min (Kingsley et al. 2006; Grove et al. 2008). Limited work has been undertaken to determine the impact of HPP on produce. HPP of strawberry puree and sliced green onions at 375 MPa for 5 min led to reductions of HAV infectivity of 4.3 and 4.8 \log_{10} respectively (Kingsley et al. 2005). At lower pressure treatments (< 350 MPa), the virus was more sensitive to pressure treatments in strawberry puree than in sliced green onions. Although HPP can be used for inactivation of HAV in certain types of produce, the impact of such treatments on the sensory qualities of the product needs to be considered (Kingsley et al. 2005). The temperature of HPP treatment can also impact on the inactivation of HAV. In experiments conducted in suspension, higher temperatures (> 30 °C) were found to increase viral inactivation at pressures between 300 and 400 MPa, while lower temperatures resulted in less inactivation (Kingsley et al. 2006).

Experiments aimed at determining the impact of HPP treatment on oysters and sausages have found that reasonable reductions in HAV levels can occur. Reductions of 3.2 \log_{10} infectivity of HAV occurred in pork sausages treated at 500 MPa for 5 min at 4 °C (Sharma et al. 2008). Treating oysters with 350 Mpa for 1 min can reduce HAV levels in oysters by more than 1 \log_{10} while treating at a higher pressure of 400 MPa for the same time reduced levels by more than 3 \log_{10} (Calci et al. 2005).

Various factors can impact on the inactivation of HAV when using HPP as higher salt concentrations have been found to have a protective effect (Grove et al. 2009) while decreasing pH enhances inactivation of HAV (Kingsley and Chen 2009). As with heat treatments, the strain used to measure the effect of HPP can also impact on the result with reductions varying from 3 to 5 \log_{10} across 4 different strains of HAV which were all treated with the same HPP conditions (Shimasaki et al. 2009).

The use of ultraviolet radiation (UV) has not only been investigated for inactivation of HAV in water but also for treatment of fresh produce. As with other treatments the type of produce and exposure time impacted on the effectiveness of the treatment. Inactivation of HAV was greater on green onions and lettuce, with doses between 40 and 240 mW s/cm² resulting in > 4 \log_{10} reductions, while the same doses applied to strawberries resulted in < 2.6 \log_{10} reductions of HAV (Fino and Kniel 2008). The surface topography of the produce was thought to be the major reason for the differences in effectiveness of UV treatment as strawberries have a rougher surface containing seed pockets which protect the viral particles from the treatment. The delivery of UV light to the produce needs to occur from both above and below the sample to ensure coverage of the entire surface (Fino and Kniel 2008). Another type of

light treatment using high intensity broad spectrum white light delivered in short bursts was also found to be able to reduce HAV in phosphate buffer by 4 log₁₀ at a dose of 0.3 J/cm² and in phosphate buffer containing serum at a dose of 1 J/cm² (Roberts and Hope 2003) Gamma irradiation has been used on produce for disinfestation and inhibition of sprouting at doses up to 1 kGy. At this level of treatment HAV levels were reduced by about 0.2 log₁₀ on lettuce and strawberries. Larger doses of between 2.7 and 3 kGy were required to reduce HAV levels by 1 log₁₀ (Bidawid et al. 2000b). There is still further research required before such processing technologies can be applied on an industrial scale and the effect of these processing technologies on the quality and taste attributes of the produce also needs to be considered.

2.9 Summary

There is certainly an urgent need for appropriate methods to be developed for studying the survival and inactivation of HAV in food systems, including both recovery and detection of virus particles from environmental and food samples. In terms of identifying a standard procedure for detection of HAV, it is possible that agreement could be obtained for standardising the extraction and RT-PCR procedures for HAV detection. This would most likely involve standardisation of RNA extraction kits, choice of PCR primers, conditions for reverse transcriptase and PCR amplification and detection of PCR amplicons. However the procedures for elution of HAV from various foodstuffs, and their concentration and separation from PCR inhibitory substances are likely to remain highly variable for different foodstuffs.

The above information indicates that there is still a lot to learn about food borne viruses and the mechanisms required to inactivate them in foods. In general food borne viruses such as HAV are more resistant to environmental stress and decontamination procedures than bacteria. The most appropriate methods for limiting the contamination of foods appear to be those that prevent contact of the virus with food and food contact surfaces. The application of good agricultural practices in the field and good hygienic practices throughout the food chain will have the greatest impact for preventing contamination of food with enteric viruses (Baert et al. 2009).

3. REVIEW OF CURRENT AUSTRALIAN INDUSTRY PRACTICES IN THE MANUFACTURE OF SEMI DRIED TOMATOES

3.1 Introduction

Consumption of loose dressed semi dried tomatoes was associated with an outbreak of hepatitis A virus (HAV) in May 2009. Since that time a further outbreak also implicating semi dried tomatoes has occurred. This is the first documented outbreak of HAV associated with semi dried tomatoes and therefore a review of the current Australian industry practices used in the manufacture of semi dried and semi sun dried tomatoes was conducted. The aim of this review is to identify current practices that may lead to the introduction of HAV and those that may result in inactivation of HAV during the manufacture of semi dried tomatoes. Industry can be provided with information that may be used to prevent contamination of semi dried tomatoes with HAV according to the scope of the project as listed in Appendix A.

Staff at CSIRO were provided with a contact list of 14 companies which manufacture or import semi dried tomatoes. The information collected from these companies was current as of November and December 2009 and it is recognised that some manufacturers have changed their practices since the first outbreak of HAV occurred earlier in 2009. Some of the manufacturer's dry and dress tomatoes while others purchase frozen semi dried tomatoes from Australian or imported sources which they may dress or distribute to further companies for dressing. A total of eight companies were visited in person and a further four were contacted only by telephone. Unsuccessful attempts were made to contact the other two companies. Specific company involvement varies from manufacture using fresh tomatoes grown in Australia (3), manufacture from either fresh tomatoes or imported semi dried tomatoes (3), manufacture from imported or local frozen semi dried tomatoes only (5), and on-sellers of semi dried imported product (1). A single company imports semi sun dried tomatoes and is included within the five manufacturers above throughout this report. Larger companies supply the supermarket chains such as Woolworths and Coles as well as the food service industry. Smaller companies tend to supply mostly to the food service industry and some individual deli style operations. The time constraints and scope of this project did not allow for investigation of the supply chain through the food service industry. A number of companies export the final product and destinations include New Zealand, South East Asia and the Middle East.

Although concrete production figures are difficult to obtain, individual companies were asked to supply their own estimated production volumes. The production and import figures are therefore only approximate and should be interpreted with some caution. The volume of frozen imported semi dried tomato is estimated at 66 ton/month, the volume of Australian fresh semi dried tomato is estimated at 236 ton/month.

3.2 On farm practices

3.2.1 Australian grown tomatoes

Tomatoes used in semi dried tomato manufacture are grown on large farms in three regions of Australia: Bowen and Bundaberg in Queensland (70%) and the Goulburn Valley in Victoria (30%). One manufacturer estimated that 90% of Australian grown tomatoes are obtained from 20 large farms. The semi dried tomato industry use a very small component of the tomatoes grown annually in Australia (Appendix B).

Tomato growth is seasonal (Table 7) and manufacturers obtain tomatoes from a limited number of farms in each region according to availability. Two manufacturers reported sourcing tomatoes from one to three farms in each region over a year.

Table 7. Seasonality of tomato growth in Australia

Region	Season
Bowen	June-November
Bundaberg	October-December April-July
Goulburn Valley	January-April

Two farms were visited in Queensland during the investigation. These farms are about 250 and 600 hectares in size and employ about 80 and 600 people respectively. Both farms produce predominantly table tomatoes for sale in major supermarkets with tomatoes for semi dried tomato manufacture as a smaller part of their business. In supplying tomatoes to supermarkets, the growers are required to have documented procedures, a quality manual and food safety/HACCP plans in place which are audited every six months. A description of the key points in the growing of tomatoes which are sourced by the semi dried tomato industry appear below.

- Tomatoes are grown from seedlings in fields on bushes or trellises on land in areas used exclusively for crops
- Depending on the variety of tomato and weather conditions, plants are harvested at least twice and up to as many as 14 times over one to three months after reaching maturity at 8 to 18 weeks after planting in the fields
- Harvesting is performed by hand (reusable gloves are worn), often with the assistance of harvest aids (Figure 2)
- Tomatoes are collected into buckets and transferred to bins for transport to packing sheds

- Bins are washed with cleaning agents using high pressure spraying equipment after each use and buckets are washed with clean water and mechanical agitation less frequently
- Irrigation is achieved through watering lines in the ground at the base of the tomato plants (spraying is avoided to help prevent fungal disease)
- Water is sourced from dams, irrigation channels and bores. Microbiological testing is not performed.
- Tomatoes are fertilised through the irrigation lines using chemical nutrients. One grower reported that feedlot manure may be applied to seedlings on some farms (though there is no risk from HAV associated with the use of animal manures as HAV infects humans and not animals)
- At the shed tomatoes are treated with halogen sanitiser (at least 5 ppm for at least three minutes) to control mould growth and packed by machine into boxes or bins based on colour and size. One grower reported that 400 ppm chlorine is used with a contact time of 5 min.
- Shed equipment is washed with chemical cleaning agents at the end of each day
- Tomato pickers are a mix of local and foreign workers who arrive in and depart from Australia seasonally
- Toilet and hand washing facilities are provided in the fields for pickers
- Employment contracts include a health clause to prevent people with infectious diseases from contacting tomatoes
- Tomatoes are supplied to semi dried tomato manufacturers in 200-450 kg bins by refrigerated (8-10°C) road transport (unless supplied locally when refrigeration is not applied)



Figure 2. Harvesting tomatoes

3.2.2 Overseas grown tomatoes

No details of growing practices for imported semi dried tomatoes are available.

3.3 Manufacturing Practices

3.3.1 Use of Australian grown tomatoes

The manufacturing process for semi dried tomatoes was generally similar across the range of companies reviewed although some variations occurred between different companies. Most of these differences were related to the mechanism of washing (spray or immersion), size of cutting machines, the time and temperature of the drying process, the point at which salt is added to the tomatoes (pre or post drying), other ingredients used (oils and herbs) and packaging systems.

A typical process for using fresh tomatoes for manufacture of semi dried includes:

- Storage in delivery bins on site in refrigerated rooms or at ambient temperature until tomatoes reach target ripeness. Smaller manufacturers tend not to store tomatoes due to lack of space.
- All tomatoes are washed with chlorinated water (200 ppm). Chlorine concentration is checked with strips at half hour intervals and redosed as necessary. Exposure time varies greatly between companies from an approximate minimum of 5 min to an approximate maximum of 1 hour. Exposure to effective chlorine levels also varies with some sprayed and tumbled and some dipped. Some companies follow with a clean water rinse.
- Alignment of tomatoes by hand before cutting with machines. Machine size varies between companies from single to larger multi unit cutters, hence the amount of handling may vary
- Hand alignment of cut tomatoes on drying trays (most companies) Figure 3
- A few companies salt the tomatoes before drying
- Drying in temperature and moisture controlled rooms varies between companies. All companies visually inspect or weigh product for final drying. The range of heat treatments used for semi dried tomatoes are listed below and depend on the manufacturer
 - 70°C / 11 h
 - 57°C / 12-14 h
 - 60-65°C / 12 h
 - 65°C / 12-13 h
 - 55-60°C / 8 h
 - 65°C / 10-12 h
- Mixing semi dried tomatoes with herbs (eg basil, oregano and parsley), salt, garlic and canola oil
- Packaging into sealed containers with or without canola oil as pack filler.



Figure 3. Tomatoes on racks before drying

All factories

- Have documented processes and accredited HACCP plans in place which are audited every six months
- Require process workers to report infectious diseases (condition of employment), wear provided clean protective outer garments including disposable gloves, and some companies also provide plastic sleeves and aprons when handling tomatoes post washing
- Have cleaning schedules which include washing and sanitising equipment with food grade cleaning agents and sanitisers purchased from reputable companies and used according to recommended guidelines. All companies do a complete clean and apply sanitiser at least at the end of each day of production
- Monitor and adjust concentrations of sanitisers
- Pack in retail and/or bulk packs which may include buckets, trays or bags
- Have fully traceable systems in place to link source and quantity of tomatoes and ingredients to production batch, production line and distribution chain

- Are actively changing practices to reduce risk of HAV contamination
- Have end product testing programs in place which consist of microbiological testing. Some companies include other variables such as pH or Brix. Testing programs are conducted with variable frequency depending on customer or audit requirements

Some factories

- Require process workers to be vaccinated against HAV
- Require process workers to wear face masks
- Segregate washing, cutting and packing more thoroughly than others
- Freeze semi dried tomatoes for later dressing and packaging which they may carry out themselves or supply to other manufacturers
- Are roasting fresh minced garlic
- Dress tomatoes with vinegar rather than oil as a low fat variety
- Pack by hand and others by automated lines
- Use modified packaging techniques eg modified atmosphere packaging and vacuum sealing
- Are using or moving to introduce steam sterilised herbs (this may result in recipe changes e.g. deletion of parsley as it is not available as a steam sterilised product). Others are staying with their long term suppliers.
- Have introduced HAV testing on end product. Some currently indicated testing of all batches of product either before manufacture (imported tomatoes) or release (Australian tomatoes)
- Have footbaths with sanitisers at entrances to processing rooms

Other information

- Manufacturers have revised their production practices since the HAV outbreaks in accordance with advice from the Notice of order under the food act – Semi dried tomatoes. Consequently they apply a 200 ppm chlorine wash for at least 3 min at the commencement of the manufacturing process. Lower concentrations of chlorine were used in wash water prior to the directive or other product such as peracetic acid. Some concerns were expressed about the potential of the higher concentration of chlorine to corrode equipment and affect the health of employees

- There is a single importer of semi sun dried tomatoes and a suggestion that there may be two companies that manufacture sun dried tomatoes in Australia. Time constraints did not allow for contacting these manufacturers
- It was estimated by one manufacturer that 90% of semi dried tomatoes are prepared from Australian tomatoes. These are predominantly sold within Australia
- Factories employ between 5 and 70 people on their manufacturing lines.
- At least four other companies not on the original contact list are involved in semi dried tomato manufacture

3.3.2 Manufacture of semi dried tomatoes from imported tomatoes

Six manufacturers that use and/or import semi dried tomatoes were visited and two were contacted by telephone. The amount known about the manufacturing process prior to receipt of product varied amongst Australian manufacturers from those that relied on the importer, to those that had visited the overseas suppliers and reviewed their processes. In general most imported product is sourced from a few companies in Turkey. Although some manufacturers had imported product from countries such as South Africa in the past, this had ceased since the time of the first outbreak of HAV associated with semi dried tomatoes in Australia and was not occurring at the time the information was gathered for this report.

In general:

- Product is sourced in a frozen state from the Izmir region of Turkey. Other regions which manufacture semi dried tomatoes include South Africa and Chile, but no recent purchases from these countries were reported
- Product is defrosted as required and dressed and packed in a similar manner as the manufacturers that use Australian tomatoes
- Australian manufacturers using imported products have documented processes and audited HACCP plans in place.
- Drying conditions in Turkey at the largest exporter are 82-85°C for 2 h followed by 55°C for 6 h. For imported semi sun dried the tomatoes are dried for 30 h at an average temperature of 45°C
- Factories employ between 5 -20 processors

A typical process for use of frozen semi dried tomatoes includes the following:

- The imported product arrives as semi dried tomatoes in a frozen state, generally in 10kg cartons

- There is a single major importer that supplies smaller manufacturers but at least two larger companies import directly for semi dried tomato production. Semi sun dried tomatoes are imported by a single company
- Cartons are defrosted in cold rooms for 3 to 4 days, as required to meet orders
- A mixture of herbs, garlic and canola oil are added and the product is repacked into smaller pack sizes
- Certificates of microbiological testing are commonly supplied with product. Some importers require HAV tests

The best practices observed for the manufacture of semi dried tomatoes from imported products included:

- Annual visits to tomato suppliers to observe and understand manufacturing practices
- Demonstrations of tomato cutting and drying being performed in modern, HACCP accredited factories under similar conditions as those applied in Australian factories (photos and documents supplied for the review)
- Hygiene standards and practices used in blending and packaging of semi dried tomatoes are of a similar standard as factories which process Australian tomatoes
- Testing of frozen product received from Turkey for HAV
- Vaccination of process workers
- Microbiological tests on end product, water and environmental swabs
- Traceability of product from overseas shipments (batch numbers are applied to each box of frozen semi dried tomatoes in the overseas factory) through to final packaged product ready for distribution
- Certificates obtained from overseas manufacturers relating to food safety accreditation, absence of HAV and microbiological test results for batches of semi dried tomatoes supplied, process flow diagrams with heating and sanitation steps used

3.3.3 Ingredients used in the manufacture of semi dried tomatoes

A range of other ingredients are used in the manufacture of semi dried tomatoes. These ingredients include herbs, spices and oils. Some manufacturers have changed to steam sterilised herbs where possible, including, oregano and basil. A number of companies have maintained the same suppliers and purchase individual herbs in bulk or premixed herbs. Garlic is sourced in a number of forms and treatments before use

also vary. Various companies have been found to roast a form of minced garlic, dried flakes can be rehydrated in a vinegar solution for up to 3 days before use, rehydration in 85 °C water, and other companies utilise dry minced or flaked garlic without rehydration. Generally canola oil is used within this dressing mixture. Some companies use certified GMO free canola oil. In a few companies vinegar can be used in the dressing mixture or as a surface spray before the final packs are sealed.

3.4 Implications of HAV on the manufacture of semi dried tomatoes

3.4.1 Changes in practice since HAV outbreaks

Manufacturers were asked about changes in practice which have been implemented since the HAV outbreaks. These include:

- Some manufacturers stopping the use of imported tomatoes
- Washing tomatoes in water containing chlorine in accordance with the Department of Health directive. Some manufacturers had a chlorine wash procedure in place prior to the directive
- Certificates are now required from the overseas supplier to demonstrate absence of HAV
- Washing imported semi dried tomatoes in vinegar
- Some are considering pasteurisation of imported product but no evidence was found that this is currently happening
- All staff must be vaccinated against HAV
- Review of traffic flow to reduce risk of cross contamination from raw to processed areas
- Manufacturers using Australian tomatoes are considering a voluntary code of practice
- Introduction of requirement of treatments for herbs and spices eg steam sterilisation of herbs and roasting of garlic
- Treatment of the manufacturing environment with chlorine sanitiser

3.4.2 Suggestions from industry for control of HAV

Manufacturers were also asked to provide input into what could be done to reduce the risk of HAV in tomatoes. Suggestions include:

- Availability of a test locally that exclusively detects infective HAV and introduction of a standard for HAV that industry should meet
- AQIS to place more control over imported tomatoes to prevent contaminated semi dried tomatoes coming in from overseas. Supplies need to demonstrate safe harvesting and manufacturing practices.
- More controls over health and traceability of workers on farms
- Validation of chlorine inactivation treatments for HAV on tomato surfaces (to be applied during washing)
- Solutions other than pasteurisation for removing HAV are preferred to lessen product changes
- Increased knowledge and care across the whole Australian industry with acceptance requirements for imported tomatoes so that sub standard semi dried tomatoes are not sold in Australia from imported sources
- Improved knowledge about survival of HAV on tomatoes
- Australian government to be proactive in reaching agreements with Turkey on farm practices and controls for HAV
- Introduction of better/honest labelling of country of origin
- Industry should become more associated to share information and develop a code of practice with independent audits
- Any industry association must include all levels of production from farm to retail and from small to large
- Factories should only obtain tomatoes from accredited growers
- The government should have more control and knowledge of safety of imported semi dried tomatoes. A third party analysis should be required.
- Imported product should be under an international HACCP accreditation with independent audits
- There should be spot checks for compliance with acceptable practice
- Research to determine effective concentration of peracetic acid for HAV inactivation on vegetables – chlorine is corrosive and its introduction is viewed as a backward step by some processes
- Inactivation temperature/time profiles for HAV in various steps of semidried tomato manufacture
- Education of public in difference between semi dried and sun dried tomatoes, that the former is carried out under safe manufacturing practices
- Differentiation between Australian and imported product and/or mixed products

3.4.3 Practices and procedures most at risk for introduction of HAV

The risks of tomatoes becoming contaminated in the field and during growing are currently unknown though contamination of produce from the use of water which may be contaminated with HAV is possible. Manufacturers should ensure they source tomatoes from growers that apply good agricultural practices in the field and during harvest. The manufacture of semi dried tomatoes requires manual handling of the product at various points throughout production, from harvesting of the tomatoes in the field, to aligning the tomatoes for the cutting machines, distributing product on drying trays etc. The most likely sources of contamination of produce with HAV are infected handlers at any point in the food chain. Therefore practices that prevent the contamination of tomatoes with HAV from food handlers and contact surfaces are likely to have the greatest impact for limiting the risk of HAV contamination. This applies to the whole industry from the farm to the final package ready for consumption.

REFERENCES

- Abad, F.X., Pinto, R.M. and Bosch, A. (1994a) Survival of enteric viruses on environmental fomites. *Appl Environ Microbiol* **60**, 3704-3710.
- Abad, F.X., Pinto, R.M., Diez, J.M. and Bosch, A. (1994b) Disinfection of human enteric viruses in water by copper and silver in combination with low levels of chlorine. *Appl Environ Microbiol* **60**, 2377-2383.
- Abbaszadegan, M., Hasan, M.N., Gerba, C.P., Roessler, P.F., Wilson, B.R., Kuennen, R. and Dellen, E.v. (1997) The disinfection efficacy of a point-of-use water treatment system against bacterial, viral and protozoan waterborne pathogens. *Water Research* **31**, 574-582.
- Amon, J.J., Devasia, R., Xia, G.L., Nainan, O.V., Hall, S., Lawson, B., Wolthuis, J.S., MacDonald, P.D.M., Shepard, C.W., Williams, I.T., Armstrong, G.L., Gabel, J.A., Erwin, P., Sheeler, L., Kuhnert, W., Patel, P., Vaughan, G., Weltman, A., Craig, A.S., Bell, B.P. and Fiore, A. (2005) Molecular epidemiology of foodborne hepatitis A outbreaks in the United States, 2003. *J Infect Dis* **192**, 1323-1330.
- Angelillo, I.F., Viggiani, N.M.A., Rizzo, L. and Bianco, A. (2000) Food handlers and foodborne diseases: Knowledge, attitudes, and reported behavior in Italy. *J Food Prot* **63**, 381-385.
- Baert, L., Debevere, J. and Uyttendaele, M. (2009) The efficacy of preservation methods to inactivate foodborne viruses. *Int J Food Microbiol* **131**, 83-94.
- Barrimah, E., Salem, K.A. and Gabal, M.S. (1999) An outbreak of hepatitis A associated with treated waste water used for irrigation. *J Egypt Public Health Assoc* **74**, 227-239.
- Becker, B., Promse, B., Kramer, J. and Exner, M. (1996) Transmission of pathogenic human viruses by foods: hepatitis A epidemic caused by baked goods in the Euskirchen district. *Gesundheitswesen* **58**, 339-340.
- Bidawid, S., Farber, J.M. and Sattar, S.A. (2000a) Contamination of foods by food handlers: Experiments on hepatitis A virus transfer to food and its interruption. *Appl Environ Microbiol* **66**, 2759-2763.
- Bidawid, S., Farber, J.M. and Sattar, S.A. (2000b) Inactivation of hepatitis A virus (HAV) in fruits and vegetables by gamma irradiation. *Int J Food Microbiol* **57**, 91-97.
- Bidawid, S., Farber, J.M. and Sattar, S.A. (2000c) Rapid concentration and detection of hepatitis A virus from lettuce and strawberries. *J Virol Methods* **88**, 175-185.
- Bidawid, S., Farber, J.M. and Sattar, S.A. (2001) Survival of hepatitis A virus on modified atmosphere-packaged (MAP) lettuce. *Food Microbiol* **18**, 95-102.
- Bidawid, S., Farber, J.M., Sattar, S.A. and Hayward, S. (2000d) Heat inactivation of hepatitis A virus in dairy foods. *J Food Prot* **63**, 522-528.

REFERENCES

- Bigliardi, L. and Sansebastiano, G. (2006) Study on inactivation kinetics of hepatitis A virus and enteroviruses with peracetic acid and chlorine. New ICC/PCR method to assess disinfection effectiveness. *J Prev Med Hyg* **47**, 56-63.
- Biziagos, E., Passagot, J., Crance, J.M. and Deloince, R. (1988) Long-term survival of hepatitis A virus and poliovirus type 1 in mineral water. *Appl Environ Microbiol* **54**, 2705-2710.
- Blanc, R. and Nasser, A. (1996) Effect of effluent quality and temperature on the persistence of viruses in soil. *Water Sci Technol* **33**, 237-242.
- Bloch, A.B., Stramer, S.L., Smith, J.D., Margolis, H.S., Fields, H.A., McKinley, T.W., Gerba, C.P., Maynard, J.E. and Sikes, R.K. (1990) Recovery of hepatitis A virus from a water supply responsible for a common source outbreak of hepatitis A. *American Journal of Public Health* **80**, 428-430.
- Borchardt, M.A., Bertz, P.D., Spencer, S.K. and Battigelli, D.A. (2003) Incidence of enteric viruses in groundwater from household wells in Wisconsin. *Appl Environ Microbiol* **69**, 1172-1180.
- Bosch, A. (1995) The survival of enteric viruses in the water environment. *Microbiologia* **11**, 393-396.
- Bosch, A., Lucena, F., Diez, J.M., Gajardo, R., Blasi, M. and Jofre, J. (1991) Waterborne viruses associated with hepatitis outbreak. *J Am Water Works Assoc* **83**, 80-83.
- Brassard, J., Lamoureux, L., Gagne, M.J., Poitras, E., Trottier, Y.L. and Houde, A. (2009) Comparison of commercial viral genomic extraction kits for the molecular detection of foodborne viruses. *Can J Microbiol* **55**, 1016-1019.
- Butot, S., Putallaz, T., Amoroso, R. and Sanchez, G. (2009) Inactivation of Enteric Viruses in Minimally Processed Berries and Herbs. *Appl Environ Microbiol* **75**, 4155-4161.
- Butot, S., Putallaz, T. and Sanchez, G. (2008) Effects of sanitation, freezing and frozen storage on enteric viruses in berries and herbs. *Int J Food Microbiol* **126**, 30-35.
- Calci, K.R., Meade, G.K., Tezloff, R.C. and Kingsley, D.H. (2005) High-pressure inactivation of hepatitis A virus within oysters. *Appl Environ Microbiol* **71**, 339-343.
- Calder, L., Simmons, G., Thornley, C., Taylor, P., Pritchard, K., Greening, G. and Bishop, J. (2003) An outbreak of hepatitis A associated with consumption of raw blueberries. *Epidemiol Infect* **131**, 745-751.
- Callahan, K.M., Taylor, D.J. and Sobsey, M.D. (1995) Comparative survival of hepatitis A virus, poliovirus and indicator viruses in geographically diverse seawaters. *Water Sci Technol* **31**, 189-193.
- Cao, J., Wang, Y., Song, H., Meng, Q., Sheng, L., Bian, T., Mahemuti, W., Yierhali, A., Omata, M. and Bi, S. (2009) Hepatitis A outbreaks in China during 2006: application of molecular epidemiology. *Hepatol Int* **3**, 356-363.

- Carducci, A., Battistini, R., Rovini, E. and Verani, M. (2009) Viral removal by wastewater treatment: monitoring of indicators and pathogens. *Food & Environmental Virology* **1**, 85-91.
- Casteel, M.J., Schmidt, C.E. and Sobsey, M.D. (2008) Chlorine disinfection of produce to inactivate hepatitis A virus and coliphage MS2. *Int J Food Microbiol* **125**, 267-273.
- Chalapati Rao, V., Symons, J.M., Ling, A., Wang, P., Metcalf, T.G., Hoff, J.C. and Melnick, J.L. (1988) Removal of hepatitis A virus and rotavirus by drinking water treatment. *J Am Water Works Assoc* **80**, 59-67.
- Ching, K.Z., Nakano, T., Chapman, L.E., Demby, A. and Robertson, B.H. (2002) Genetic characterization of wild-type genotype VII hepatitis A virus. *J Gen Virol* **83**, 53-60.
- Cohen, J.I., Ticehurst, J.R., Purcell, R.H., Buckler-White, A. and Baroudy, B.M. (1987) Complete nucleotide sequence of wild-type hepatitis A virus: Comparison with different strains of hepatitis A virus and other picornaviruses. *J Virol* **61**, 50-59.
- Costafreda, M.I., Bosch, A. and Pinto, R.M. (2006) Development, evaluation, and standardization of a real-time TaqMan reverse transcription-PCR assay for quantification of hepatitis A virus in clinical and shellfish samples. *Appl Environ Microbiol* **72**, 3846-3855.
- Cristina, J. and Costa-Mattioli, M. (2007) Genetic variability and molecular evolution of Hepatitis A virus. *Virus Res* **127**, 151-157.
- Croci, L., Ciccozzi, M., Medici, D.d., Pasquale, S.d., Fiore, A., Mele, A. and Toti, L. (1999) Inactivation of hepatitis A virus in heat-treated mussels. *J Appl Microbiol* **87**, 884-888.
- Croci, L., De Medici, D., Di Pasquale, S. and Toti, L. (2005) Resistance of hepatitis A virus in mussels subjected to different domestic cookings. *Int J Food Microbiol* **105**, 139-144.
- Croci, L., De Medici, D., Scalfaro, C., Fiore, A. and Toti, L. (2002) The survival of hepatitis A virus in fresh produce. *Int J Food Microbiol* **73**, 29-34.
- Croci, L., Dubois, E., Cook, N., de Medici, D., Schultz, A.C., China, B., Rutjes, S.A., Hoorfar, J. and Van der Poel, W.H.M. (2008) Current Methods for Extraction and Concentration of Enteric Viruses from Fresh Fruit and Vegetables: Towards International Standards. *Food Analytical Methods* **1**, 73-84.
- Deboosere, N., Legeay, O., Caudrelier, Y. and Lange, M. (2004) Modelling effect of physical and chemical parameters on heat inactivation kinetics of hepatitis A virus in a fruit model system. *Int J Food Microbiol* **93**, 73-85.
- Deng, M.Y., Day, S.P. and Cliver, D.O. (1994) Detection of hepatitis A virus in environmental samples by antigen-capture PCR. *Appl Environ Microbiol* **60**, 1927-1933.

REFERENCES

- Dentinger, C.M., Bower, W.A., Nainan, O.V., Cotter, S.M., Myers, G., Dubusky, L.M., Fowler, S., Salehi, E.D.P. and Bell, B.P. (2001) An outbreak of hepatitis A associated with green onions. *J Infect Dis* **183**, 1273-1276.
- Dubois, E., Agier, C., Traore, O., Hennechart, C., Merle, G., Cruciere, C. and Laveran, H. (2002) Modified concentration method for the detection of enteric viruses on fruits and vegetables by reverse transcriptase-polymerase chain reaction or cell culture. *J Food Prot* **65**, 1962-1969.
- Dubois, E., Hennechart, C., Deboosere, N., Merle, G., Legeay, O., Burger, C., Calve, M.I., Lombard, B., Ferre, V. and Traore, O. (2006) Intra-laboratory validation of a concentration method adapted for the enumeration of infectious F-specific RNA coliphage, enterovirus, and hepatitis A virus from inoculated leaves of salad vegetables. *Int J Food Microbiol* **108**, 164-171.
- Eisenstein, A.B., Aach, R.D., Jacobsohn, W. and Goldman, A. (1963) An epidemic of infectious Hepatitis in a general hospital. Probable transmission by contaminated orange juice. *J Am Med Assoc* **185**, 171-174.
- Endo, K., Inoue, J., Takahashi, M., Mitsui, T., Masuko, K., Akahane, Y. and Okamoto, H. (2007a) Analysis of the full-length genome of a subgenotype IIIB hepatitis A virus isolate: primers for broadly reactive PCR and genotypic analysis. *J Med Virol* **79**, 8-17.
- Endo, K., Takahashi, M., Masuko, K., Inoue, K., Akahane, Y. and Okamoto, H. (2007b) Full-length sequences of subgenotype IIIA and IIIB hepatitis A virus isolates: characterization of genotype III HAV genomes. *Virus Res* **126**, 116-127.
- Enriquez, C.E., Hurst, C.J. and Gerba, C.P. (1995) Survival of the enteric adenoviruses 40 and 41 in tap, sea, and waste water. *Water Research* **29**, 2548-2553.
- Fino, V.R. and Kniel, K.E. (2008) UV light inactivation of hepatitis A virus, Aichi virus, and feline calicivirus on strawberries, green onions, and lettuce. *J Food Prot* **71**, 908-913.
- Frank, C., Walter, J., Muehlen, M., Jansen, A., Treeck, U.v., Hauri, A.M., Zoellner, I., Rakha, M., Hoehne, M., Hamouda, O., Schrier, E. and Stark, K. (2007) Major outbreak of hepatitis A associated with orange juice among tourists, Egypt, 2004. *Emerging Infect Dis* **13**, 156-158.
- Gerba, C.P., Pepper, I.L. and Whitehead, L.F. (2002) A risk assessment of emerging pathogens of concern in the land application of biosolids. *Water SciTechnol* **46**, 225-230.
- Grabow, W.O.K., Gauss-Mueller, V., Prozesky, O.W. and Deinhardt, F. (1983) Inactivation of hepatitis A virus and indicator organisms in water by free chlorine residuals. *Appl Environ Microbiol* **46**, 619-624.
- Grove, S.F., Forsyth, S., Wan, J., Coventry, J., Cole, M., Stewart, C.M., Lewis, T., Ross, T. and Lee, A. (2008) Inactivation of hepatitis A virus, poliovirus and a norovirus surrogate by high pressure processing. *Innov Food Sci Emerg Technol* **9**, 206-210.

- Grove, S.F., Lee, A., Stewart, C.M. and Ross, T. (2009) Development of a High Pressure Processing Inactivation Model for Hepatitis A Virus. *J Food Prot* **72**, 1434-1442.
- Hall, R.M. and Sobsey, M.D. (1993) Inactivation of Hepatitis-a Virus and Ms2 by Ozone and Ozone-Hydrogen Peroxide in Buffered Water. *Water SciTechnol* **27**, 371-378.
- Hasegawa, Y., Matsumoto, F., Tanaka, C., Ouchi, Y. and Hayashi, K. (2007) Outbreak of hepatitis A virus infection caused by food served in a restaurant. *Jpn J Infect Dis* **60**, 150-151.
- Hedachin, A.E., Doskina, T.V., Dmitrieva, R.A. and Kazachkov, Y.A. (1993) Influence of various chlorine doses on inactivation of hepatitis A virus in water. *Gigiena i Sanitariya* **10**, 23-24.
- Herbold, K., Flehmig, B. and Botzenhart, K. (1989) Comparison of ozone inactivation, in flowing water, of hepatitis A virus, poliovirus 1, and indicator organisms. *Appl Environ Microbiol* **55**, 2949-2953.
- Heywood, P., Cutler, J., Burrows, K., Komorowski, C., Marshall, B. and Wang, H.L. (2007) A community outbreak of travel-acquired hepatitis A transmitted by an infected food handler. *Can Commun Dis Rep* **33**, 16-22.
- Howitz, M., Mazick, A. and Molbak, K. (2005) Hepatitis A outbreak in a group of Danish tourists returning from Turkey, October 2005. *Euro Surveill* **10**.
- Hu, Y. and Arsov, I. (2009) Nested real-time PCR for hepatitis A detection. *Lett Appl Microbiol* **49**, 615-619.
- Hutin, Y.J.F., Pool, V., Cramer, E.H., Nainan, O.V., Weth, J., Williams, I.T., Goldstein, S.T., Gensheimer, K.F., Bell, B.P., Shapiro, C.N., Alter, M.J., Margolis, H.S. and Natl Hepatitis, A.I.T. (1999) A multistate, foodborne outbreak of hepatitis A. *N Engl J Med* **340**, 595-602.
- Jean, J., Vachon, J.F., Moroni, O., Darveau, A., Kukavica-Ibrulj, I. and Fliss, I. (2003) Effectiveness of commercial disinfectants for inactivating hepatitis A virus on agri-food surfaces. *J Food Prot* **66**, 115-119.
- Jia, X.-Y., Ehrenfeld, E. and Summers, D.F. (1991) Proteolytic activity of hepatitis A virus 3C protein. *J Virol* **65**, 2595-2600.
- John, D.E. and Rose, J.B. (2005) Review of factors affecting microbial survival in groundwater. *Environ Sci Technol* **39**, 7345-7356.
- Khadre, M.A., Yousef, A.E. and Kim, J.G. (2001) Microbiological aspects of ozone applications in food: A review. *J Food Sci* **66**, 1242-1252.
- Kingsley, D.H. and Chen, H. (2009) Influence of pH, salt, and temperature on pressure inactivation of hepatitis A virus. *Int J Food Microbiol* **130**, 61-64.
- Kingsley, D.H., Dongsheng, G. and Hoover, D.G. (2005) Pressure inactivation of hepatitis A virus in strawberry puree and sliced green onions. *J Food Prot* **68**, 1748-1751.

REFERENCES

- Kingsley, D.H., Dongsheng, G., Hoover, D.G. and Haiqiang, C. (2006) Inactivation of hepatitis A virus by high-pressure processing: the role of temperature and pressure oscillation. *J Food Prot* **69**, 2454-2459.
- Kittigul, L., Uthaisin, A., Ekchaloemkiet, S., Utarachkij, F. and Luksamijarulkul, P. (2006) Detection and characterization of hepatitis A virus in water samples in Thailand. *J Appl Microbiol* **100**, 1318-1323.
- Koopmans, M. and Duizer, E. (2004) Foodborne viruses: an emerging problem. *Int J Food Microbiol* **90**, 23-41.
- Kukavica-Ibrulj, I., Darveau, A., Jean, J. and Fliss, I. (2004) Hepatitis A virus attachment to agri-food surfaces using immunological, virological and thermodynamic assays. *J Appl Microbiol* **97**, 923-934.
- LaPorte, T., Heisey-Grove, D., Kludt, P., Matyas, B.T., DeMaria, A., Jr., Dicker, R., De, A., Fiore, A., Nainan, O. and Friedman, D.S. (2003) Foodborne transmission of hepatitis A - Massachusetts, 2001. *Morb Mortal Weekly Rep* **52**, 565-567.
- Li, J.W., Xin, Z.T., Wang, X.W., Zheng, J.L. and Chao, F.H. (2002) Mechanisms of inactivation of hepatitis A virus by chlorine. *Appl Environ Microbiol* **68**, 4951-4955.
- Love, D.C., Casteel, M.J., Meschke, J.S. and Sobsey, M.D. (2008) Methods for recovery of hepatitis A virus (HAV) and other viruses from processed foods and detection of HAV by nested RT-PCR and TaqMan RT-PCR. *Int J Food Microbiol* **126**, 221-226.
- Lowry, P.W., Levine, R., Stroup, D.F., Gunn, R.A., Wilder, M.H. and Konigsberg, C., Jr. (1989) Hepatitis A outbreak on a floating restaurant in Florida, 1986. *Am J Epidemiol* **129**, 155-164.
- Lu, L., Ching, K.Z., de Paula, V.S., Nakano, T., Siegl, G., Weitz, M. and Robertson, B.H. (2004a) Characterization of the complete genomic sequence of genotype II hepatitis A virus (CF53/Berne isolate). *J Gen Virol* **85**, 2943-2952.
- Lu, L., Ching, K.Z., de Paula, V.S., Nakano, T., Siegl, G., Weitz, M. and Robertson, B.H. (2004b) Characterization of the complete genomic sequence of genotype II hepatitis A virus (CF53/Berne isolate). *J Gen Virol* **85**, 2943-2952.
- Mariam, T.W. and Cliver, D.O. (2000) Hepatitis A virus control in strawberry products. *Dairy, Food & Environmental Sanitation* **20**, 612-616.
- Mbithi, J.N., Springthorpe, V.S., Boulet, J.R. and Sattar, S.A. (1992) Survival of hepatitis A virus on human hands and its transfer on contact with animate and inanimate surfaces. *J Clin Microbiol* **30**, 757-763.
- Mbithi, J.N., Springthorpe, V.S. and Sattar, S.A. (1990) Chemical disinfection of hepatitis A virus on environmental surfaces. *Appl Environ Microbiol* **56**, 3601-3604.
- Mbithi, J.N., Springthorpe, V.S. and Sattar, S.A. (1991) Effect of relative humidity and air temperature on survival of hepatitis A virus on environmental surfaces. *Appl Environ Microbiol* **57**, 1394-1399.

- Mbithi, J.N., Springthorpe, V.S. and Sattar, S.A. (1993) Comparative in vivo efficiencies of hand-washing agents against hepatitis A virus (HM-175) and poliovirus type 1 (Sabin). *Appl Environ Microbiol* **59**, 3463-3469.
- Morace, G., Pisani, G., Divizia, M. and Pana, A. (1993) Detection of hepatitis A virus in concentrated river water by polymerase chain reaction. *Zentralblatt fuer Hygiene und Umweltmedizin* **193**, 521-527.
- Mukomolov, S.L., Parkov, O.V., Davidkin, I., Sologub, T.V., Zheleznova, N.V., Chkhinzheriia, I.G., Broman, M. and Dudina, A. (2008) Molecular-epidemiologic characteristic of hepatitis A outbreak among workers of food stores network. *Zh Mikrobiol Epidemiol Immunobiol*, 42-45.
- Nainan, O.V., Gouliang, X., Vaughan, G. and Margolis, H.S. (2006) Diagnosis of hepatitis A virus infection and identification of food source: a molecular approach. *Clin Microbiol Rev* **19**, 63-79.
- Nasser, A.M. (1994) Prevalence and fate of hepatitis A virus in water. *Critical Reviews in Environmental Science & Technology* **24**, 281-323.
- Niu, M.T., Polish, L.B., Robertson, B.H., Khanna, B.K., Woodruff, B.A., Shapiro, C.N., Miller, M.A., Smith, J.D., Gedrose, J.K., Alter, M.J. and et al. (1992) Multistate outbreak of hepatitis A associated with frozen strawberries. *J Infect Dis* **166**, 518-524.
- Nuanualsuwan, S. and Cliver, D.O. (2003) Capsid functions of inactivated human picornaviruses and feline calicivirus. *Appl Environ Microbiol* **69**, 350-357.
- Nuanualsuwan, S., Mariam, T., Himathongkham, S. and Cliver, D.O. (2002) Ultraviolet inactivation of feline calicivirus, human enteric viruses and coliphages. *Photochem Photobiol* **76**, 406-410.
- Papafragkou, E., Plante, M., Mattison, K., Bidawid, S., Karthikeyan, K., Farber, J.M. and Jaykus, L.A. (2008) Rapid and sensitive detection of hepatitis A virus in representative food matrices. *J Virol Methods* **147**, 177-187.
- Park, S.H., Kim, E.J., Lee, J.H., Choi, S.S., Kim, M.S., Jung, S.S., Han, G.Y., Yun, H.S., Chun, D.S., Oh, S.S. and Kim, H.S. (2009) Molecular characterization of hepatitis A virus isolated from acute gastroenteritis patients in the Seoul region of Korea. *Eur J Clin Microbiol Infect Dis* **28**, 1177-1182.
- Perevoscikovs, J., Lucenko, I., Magone, S. and Brila, A. (2008) Increase in hepatitis A cases in Latvia, in 2008, including an ongoing outbreak associated with a restaurant in Riga--preliminary report. *Euro Surveill* **13**.
- Pipat, L., Varaporn, P. and Supornwit, P. (1994) Microbiological quality of drinking water and using water of a Chao Phya River community, Bangkok. *Southeast Asian Journal of Tropical Medicine & Public Health* **25**, 633-637.
- Prato, R., Lopalco, P.L., Chironna, M., Germinario, C. and Quarto, M. (2006) An outbreak of hepatitis A in Southern Italy: the case for vaccinating food handlers. *Epidemiol Infect* **134**, 799-802.

REFERENCES

- Probst, C., Jecht, M. and Gauss-Mueller, V. (1999) Intrinsic signals for the assembly of hepatitis A virus particles. Role of structural proteins VP4 and 2A. *J Biol Chem* **274**, 4527-4531.
- Ramsay, C.N. and Upton, P.A. (1989) Hepatitis A and frozen raspberries. *Lancet* **1**, 43-44.
- Reid, T.M. and Robinson, H.G. (1987) Frozen raspberries and hepatitis A. *Epidemiol Infect* **98**, 109-112.
- Roberts, P. and Hope, A. (2003) Virus inactivation by high intensity broad spectrum pulsed light. *J Virol Methods* **110**, 61-65.
- Robertson, B.H., Jansen, R.W., Khanna, B., Totsuka, A., Nainan, O.V., Siegl, G., Widell, A., Margolis, H.S., Isomura, S., Ito, K., Ishizu, T., Moritsugu, Y. and Lemon, S.M. (1992) Genetic relatedness of hepatitis A virus strains recovered from different geographical regions. *J Gen Virol* **73**, 1365-1377.
- Robesyn, E., De Schrijver, K., Wollants, E., Top, G., Verbeeck, J. and Van Ranst, M. (2009) An outbreak of hepatitis A associated with the consumption of raw beef. *J Clin Virol* **44**, 207-210.
- Rosenblum, L.S., Mirkin, I.R., Allen, D.T., Safford, S. and Hadler, S.C. (1990) A multifocal outbreak of hepatitis A traced to commercially distributed lettuce. *Am J Public Health* **80**, 1075-1079.
- Rowe, S.L., Tanner, K. and Gregory, J.E. (2009) Hepatitis a outbreak epidemiologically linked to a food handler in Melbourne, Victoria. *Commun Dis Intell* **33**, 46-48.
- Rzeutka, A., D'Agostino, M. and Cook, N. (2006) An ultracentrifugation-based approach to the detection of hepatitis A virus in soft fruits. *Int J Food Microbiol* **108**, 315-320.
- Rzeutka, A. and Cook, N. (2004) Survival of human enteric viruses in the environment and food. *Fems Microbiol Rev* **28**, 441-453.
- Sair, A.I., D' Souza, D.H. and Jaykus, L.A. (2002) Human enteric viruses as causes of foodborne disease. *Comprehensive Reviews in Food Science & Food Safety* **1**, 73-89.
- Sanchez, G., Aragonés, L., Costafreda, M.I., Ribes, E., Bosch, A. and Pinto, R.M. (2004) Capsid Region Involved in Hepatitis A Virus Binding to Glycophorin A of the Erythrocyte Membrane. *J Virol* **78**, 9807-9813.
- Sattar, S.A., Springthorpe, V.S., Tetro, J., Vashon, R. and Keswick, B. (2002) Hygienic hand antiseptics: Should they not have activity and label claims against viruses? *Am J Infect Control* **30**, 355-372.
- Sattar, S.A., Tetro, J., Bidawid, S. and Farber, J. (2000) Foodborne spread of hepatitis A: recent studies on virus survival, transfer and inactivation. *Can J Infect Dis* **11**, 159-163.

- Schenkel, K., Bremer, V., Grabe, C., Van Treeck, U., Schreier, E., Hohne, M., Ammon, A. and Alpers, K. (2006) Outbreak of hepatitis A in two federal states of Germany: bakery products as vehicle of infection. *Epidemiol Infect* **134**, 1292-1298.
- Schmid, D., Fretz, R., Buchner, G., Konig, C., Perner, H., Sollak, R., Tratter, A., Hell, M., Maass, M., Strasser, M. and Allerberger, F. (2009) Foodborne outbreak of hepatitis A, November 2007-January 2008, Austria. *Eur J Clin Microbiol Infect Dis* **28**, 385-391.
- Schoenbaum, S.C., Baker, O. and Jezek, Z. (1976) Common-source epidemic of hepatitis due to glazed and iced pastries. *Am J Epidemiol* **104**, 74-80.
- Schwarz, N.G., Revillion, M., Roque-Afonso, A.M., Dussaix, E., Giraud, M., Liberpre, C., Couturier, E. and Delarocque Astagneau, E. (2008) A food-borne outbreak of hepatitis A virus (HAV) infection in a secondary school in Upper Normandy, France, in November 2006. *Eurosurveillance* **13**.
- Serracca, L., Gallo, F., Rossini, I., Benedetto, A., Lacerenza, D., Callipo, M.R., Monnier, M. and Gorla, M. (2009) Official surveillance of hepatitis A virus: description of an HAV detection method in shellfish. *Food & Environmental Virology* **1**, (2):97-104.
- Sharma, M., Shearer, A.E.H., Hoover, D.G., Liu, M.N., Solomon, M.B. and Kniel, K.E. (2008) Comparison of hydrostatic and hydrodynamic pressure to inactivate foodborne viruses. *Innov Food Sci Emerg Technol* **9**, 418-422.
- Shieh, Y.C., Stewart, D.S. and Laird, D.T. (2009) Survival of Hepatitis A Virus in Spinach during Low Temperature Storage. *J Food Prot* **72**, 2390-2393.
- Shimasaki, N., Kiyohara, T., Totsuka, A., Nojima, K., Okada, Y., Yamaguchi, K., Kajioka, J., Wakita, T. and Yoneyama, T. (2009) Inactivation of hepatitis A virus by heat and high hydrostatic pressure: variation among laboratory strains. *Vox Sanguinis* **96**, 14-19.
- Sidhu, J.P.S. and Toze, S.G. (2009) Human pathogens and their indicators in biosolids: A literature review. *Environ Int* **35**, 187-201.
- Sobsey, M.D., Hall, R.M. and Hazard, R.L. (1995) Comparative reductions of hepatitis A virus, enteroviruses and coliphage MS2 in miniature soil columns. *Water Sci Technol* **31**, 203-209.
- Solomon, E.B., Fino, V., Wei, J. and Kniel, K.E. (2009) Comparative susceptibilities of hepatitis A virus, feline calicivirus, bacteriophage MS2 and bacteriophage Phi X-174 to inactivation by quaternary ammonium and oxidative disinfectants. *Int J Antimicrob Agents* **33**, 288-289.
- Stine, S.W., Inhong, S., Choi, C.Y. and Gerba, C.P. (2005a) Application of microbial risk assessment to the development of standards for enteric pathogens in water used to irrigate fresh produce. *J Food Prot* **68**, 913-918.
- Stine, S.W., Song, I., Choi, C.Y. and Gerba, C.P. (2005b) Effect of relative humidity on preharvest survival of bacterial and viral pathogens on the surface of cantaloupe, lettuce, and bell peppers. *J Food Prot* **68**, 1352-1358.

REFERENCES

- Terpstra, F.G., van den Blink, A.E., Bos, L.M., Boots, A.G.C., Brinkhuis, F.H.M., Gijzen, E., van Remmerden, Y., Schuitemaker, H. and van 't Wout, A.B. (2007) Resistance of surface-dried virus to common disinfection procedures. *J Hosp Infect* **66**, 332-338.
- Tesar, M., Pak, I., Jia, X.-Y., Richards, O.C., Summers, D.F. and Ehrenfeld, E. (1994) Expression of Hepatitis A Virus Precursor Protein P3 in Vivo and in Vitro: Polyprotein Processing of the 3CD Cleavage Site. *Virology* **198**, 524-533.
- Tsai, Y., Tran, B. and Palmer, C. (1995) Analysis of viral RNA persistence in seawater by reverse transcriptase-PCR. *Appl Environ Microbiol* **61**, 363-366.
- Vaughn, J.M., Chen, Y.S., Novotny, J.F. and Strout, D. (1990) Effects of Ozone Treatment on the Infectivity of Hepatitis-a Virus. *Can J Microbiol* **36**, 557-560.
- Venter, J.M.E., Heerden, J.v., Vivier, J.C., Grabow, W.O.K. and Taylor, M.B. (2007) Hepatitis A virus in surface water in South Africa: what are the risks? *J Water Health* **5**, 229-240.
- Villar, L.M., Paula, V.S.d., Diniz Mendes, L., Guimaraes, F.R., Ferreira, F.F.M., Shubo, T.C., Miagostovich, M.P., Lampe, E. and Gaspar, A.M.C. (2007) Molecular detection of hepatitis A virus in urban sewage in Rio de Janeiro, Brazil. *Lett Appl Microbiol* **45**, 168-173.
- Weitz, M., Baroudy, B.M., Maloy, W.L., Ticehurst, J.R. and Purcell, R.H. (1986) Detection of a genome-linked protein (VPg) of hepatitis A virus and its comparison with other picornaviral VPgs. *J Virol* **60**, 124-130.
- Weltman, A.C., Bennett, N.M., Ackman, D.A., Misage, J.H., Campana, J.J., Fine, L.S., Doniger, A.S., Balzano, G.J. and Birkhead, G.S. (1996) An outbreak of hepatitis A associated with a bakery, New York, 1994: the 1968 "West Branch, Michigan" outbreak repeated. *Epidemiol Infect* **117**, 333-341.
- Wheeler, C., Vogt, T.M., Armstrong, G.L., Vaughan, G., Weltman, A., Nainan, O.V., Dato, V., Xia, G.L., Waller, K., Amon, J., Lee, T.M., Highbaugh-Battle, A., Hembree, C., Evenson, S., Ruta, M.A., Williams, I.T., Fiore, A.E. and Bell, B.P. (2005) An outbreak of hepatitis A associated with green onions. *N Engl J Med* **353**, 890-897.
- World Health Organization (2008) *Microbiological hazards in fresh leafy vegetables and herbs : meeting report*. Rome: Food and Agriculture Organization of the United Nations.
- Zoni, R., Zanelli, R., Riboldi, E., Bigliardi, L. and Sansebastiano, G. (2007) Investigation on virucidal activity of chlorine dioxide. experimental data on feline calicivirus, HAV and Coxsackie B5. *J Prev Med Hyg* **48**, 91-95.

APPENDIX A: PROJECT SCOPE

Semi-dried Tomatoes and Hepatitis A Virus

Project scope

Based on discussions with Department of Health (16th Oct, 2009) and the information provided in the semi dried tomatoes project brief, the following approach is suggested for investigating the issues surrounding semi dried tomatoes and hepatitis A virus (HAV). The project is broken into three separate parts as detailed below.

1. Review of industry practices

Aim: to establish current Australian industry practices in the manufacture of semi dried and semi sun dried tomatoes

Estimated time for completion – 6 weeks, briefing on progress after 4 weeks

A survey of the industry will be conducted to determine current through chain practices in the growing, importing and manufacture of semi dried and semi sun dried tomatoes. The industry contacts provided by Department of Health will form the basis for initial communication with the industry. Quantitative information will be obtained where appropriate and where possible. This will include but will not be limited to information on the following:

- general industry overview (volume of productions, size of industry, numbers of producers, manufacturers, importers etc)
- on-farm practices (irrigation, washing, water sources, risk management practices etc)
- manufacturers (mix of domestic vs imported product, other ingredients and supply chain, drying protocols etc)
- general production treatments (drying practices, washes etc)
- importation (requirements, traceability, seasonality)
- current microbiological specifications and acceptance criteria (if any)
- current documented procedures (processes, accreditation, certification, HACCP, traceability)
- identification of practices and procedures most at risk for introduction of HAV

2. Hepatitis A Virus survival and control

Aim: to determine current state of knowledge on methods for controlling food borne viruses in horticulture products

Estimated time for completion – 4 weeks

This will involve a survey of the current literature and available information on the survival characteristics of HAV and current methods for controlling HAV in high risk foods. This may be expanded to include other food borne viruses if appropriate. This will include information on the following:

- methods for testing for HAV (molecular and infectivity assays, issues for data interpretation, use of surrogates)

- heat and chemical treatments required to inactivate HAV
- survival on plant material
- survival and control in water
- survival in other ingredients used for manufacture of semi dried tomatoes

3. Recommendations

Estimated time for completion – 1 week after completion of the review of industry practices

Based on the information obtained from parts 1 and 2, a set of recommendations will be provided, this will include:

- recommendations to industry for immediate implementation to reduce the risk of HAV from semi dried and semi sun dried tomatoes (consideration will be given to methods that will have minimal impact on product quality and can be achieved with minimal cost).
- recommendations to the industry for longer term strategies to limit contamination of HAV in semi dried tomatoes and semi sun dried tomatoes (such as recommending the development of an industry code of practice)
- current gaps in knowledge and recommendations for future research and further actions for both regulators and industry.

The findings associated with this work have the potential to be applicable to other industries and also other viral pathogens. The information will be provided to the Department of Health and then disseminated to industry. Confidentiality of the individual companies will be maintained and names will not be provided in the document.

APPENDIX B: AUSTRALIAN TOMATO PRODUCTION STATISTICS

Table 8. The percentage of Australian tomato production per state for 2007-2008 (based on Australian Bureau of Statistics data)

	NSW	ACT	VIC	QLD	SA	WA	TAS	NT
Total (tomatoes for processing and fresh market)								
Total area sown (ha)	13%	0%	44%	37%	1%	4%	0%	0%
Total production (t)	12%	0%	46%	35%	4%	3%	0%	0%
Tomatoes - processing								
Area sown (ha)	16%	0%	80%	3%	0%	1%	0%	0%
Production (t)	12%	0%	86%	2%	0%	0%	0%	0%
Tomatoes - fresh market								
Area sown (ha)	12%	0%	22%	59%	2%	6%	0%	0%
Outdoor area sown (ha)	11%	0%	22%	61%	0%	6%	0%	0%
Undercover - area sown (m ²)	30%	0%	21%	7%	36%	2%	3%	0%
Total production (t)	12%	0%	20%	56%	6%	5%	0%	0%
Outdoor - total production (t)	11%	0%	20%	63%	0%	6%	0%	0%
Undercover - total production (kg)	23%	0%	19%	10%	46%	0%	1%	0%

APPENDIX B: AUSTRALIAN TOMATO PRODUCTION STATISTICS

Table 9. Area used for growth and tonnage of tomato production in Australia for 2007-2008 (based on Australian Bureau of Statistics data)

	NSW	ACT	VIC	QLD	SA	WA	TAS	NT	Australia total
Total (tomatoes for processing and fresh market)									
Total area sown (ha)	903	0	2,996	2,543	85	259	8	1	6,796
Total production (t)	46,848	2	174,379	132,444	14,808	12,317	997	30	381,824
Tomatoes - processing									
Area sown (ha)	409	0	2076	78	4	16	0	0	2,583
Production (t)	17,935	0	126,946	2,297	93	273	0	0	147,544
Tomatoes - fresh market									
Total area sown (ha)	494	0	919	2,466	81	244	8	1	4,213
Outdoor - area sown (ha)	436	0	878	2,452	11	240	2	1	4,020
Undercover - area sown (m ²)	580,375	0	410,649	140,766	702439	37,334	62,244	0	1,933,807
Total production (t)	28,913	2	47,433	130,147	14715	12,044	997	30	234,280
Outdoor - total production (t)	21,787	2	41,335	127,087	202	11,987	537	30	202,967
Undercover - total production (kg)	7,125,122	0	6,097,853	3,060,113	14,513,298	56,691	459,935	0	31,313,012

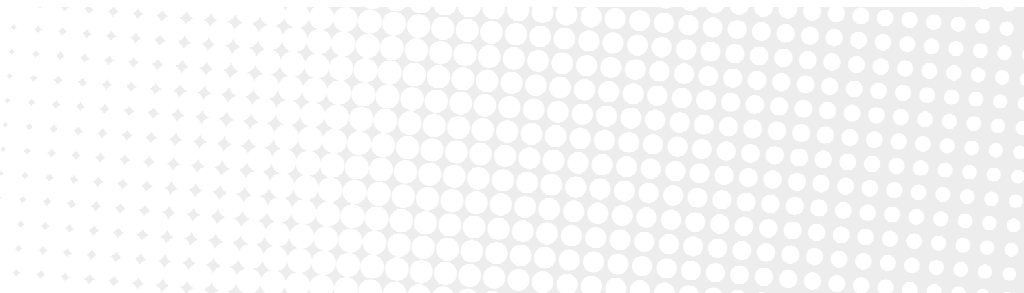

Contact Us

Phone: 1300 363 400

+61 3 9545 2176

Email: enquiries@csiro.au

Web: www.csiro.au

Your CSIRO

Australia is founding its future on science and innovation. Its national science agency, CSIRO, is a powerhouse of ideas, technologies and skills for building prosperity, growth, health and sustainability. It serves governments, industries, business and communities across the nation.